

DESIGN GUIDELINES  
FOR  
OLD SIXTH WARD  
PROTECTED HISTORIC  
DISTRICT  
HOUSTON, TEXAS

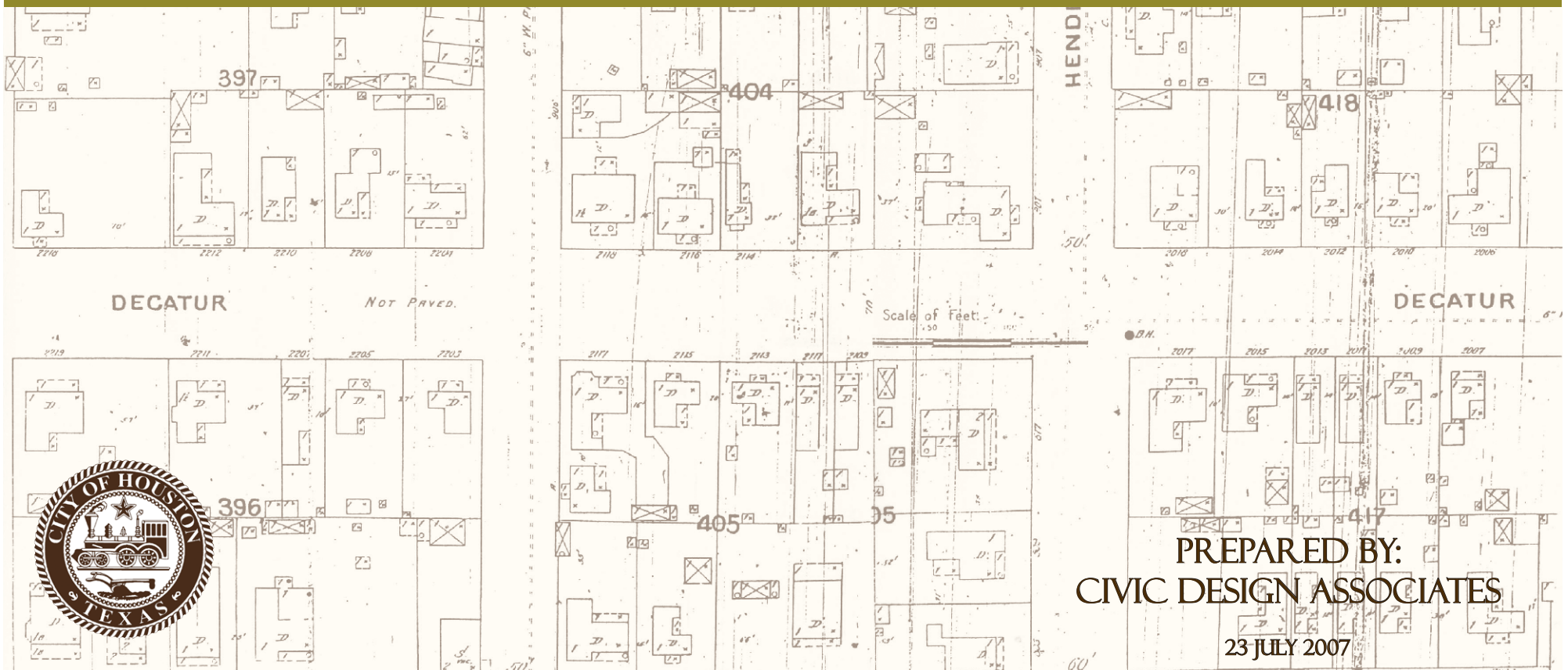

## **Acknowledgements**

### **The City of Houston, Texas**

**Mayor**            Bill White

### **City Council**

At-Large 1     Peter Brown  
At-Large 2     Sue Lovell  
At-Large 3     Melissa Noriega  
At-Large 4     Ronald C. Green  
At-Large 5     Michael Berry

District A     Toni Lawrence  
District B     Jarvis Johnson  
District C     Anne Clutterbuck  
District D     Ada Edwards  
District E     Addie Wiseman  
District F     M. J. Khan, P. E.  
District G     Pam Holm  
District H     Adrian Garcia  
District I     Carol Alvarado

Controller     Annise D. Parker

### **Houston Archaeological and Historical Commission**

Betty Trapp Chapman, Chair  
Phoebe Tudor, Vice Chair  
Marlene L. Gafrick, Secretary  
Faye B. Bryant  
Rafael Longoria  
Sharie Beale  
Roger G. Moore  
J. D. Bartell  
C. K. Pang  
Suraiya Saleem  
Paul Fruge Jr.  
Scott Slaney

The Old Sixth Ward Neighborhood Association provided invaluable support in the research and documentation of the existing historic structures in the District, and prepared a draft guideline document. Portions of it have been incorporated into this document by permission. The draft document was prepared by J. D. Bartell, with contributions by Jane Cahill and Chuck Stava.

Portions of other regulatory and guideline documents have been incorporated in this document for convenience and reference. These include primarily:

Chapter 33, The City of Houston Code of Ordinances

The Secretary of the Interior's Standards for the Treatment of Historic Properties

**TABLE OF CONTENTS**

**I. Introduction and General Information.....1**

**II. How to Use these Design Guidelines .....4**

**III. Construction Treatments .....8**

**IV. Site Development Standards .....14**

**V. Building Elements and Details .....27**

**VI. Historic Restoration..... 38**

**Appendices**

## **I. Introduction and General Information**

### **A. Purpose and Goals**

Old Sixth Ward represents the greatest concentration of historic homes in the City of Houston. Its proximity to downtown, along with the increasing interest in redeveloping inner city areas, has resulted in a surge of development activity around and within the District. These design guidelines have been developed and adopted by the City of Houston in order to promote the following goals and objectives:

- To preserve the existing building stock and general neighborhood character of Old Sixth Ward.
- To allow for the orderly and compatible alteration of existing historic properties in the District in a manner that protects and enhances the building or structure.
- To provide for new infill development and additions that are compatible with the surrounding historic structures and preserve the existing neighborhood character.

The expressed purpose of these design guidelines is to describe and define, both in narrative and illustrative form, the type of construction, alteration, and restoration that is considered appropriate for the District. Careful attention to the intent and content of these guidelines, with appropriate consultation and review by city staff and the HAHC, will assist in the granting of a Certificate of Appropriateness, and more importantly, in the preservation and enhancement of the Old Sixth Ward.

Old Sixth Ward owes its character to several factors:

- A traditional grid of streets that defines a series of regular, rectangular blocks: This approach actually yields a great deal of variety and interest, since the grid allows for a variety of lot sizes and orientations. Also, uses are mixed, with commercial establishments and churches interspersed among the residential uses.
- A building stock that, to this day, represents a historical period reflective of Houston's formative years: Many of the buildings standing today were built between 1870 and 1900. While there is great variety in typology and detail, these historic structures are generally based on a vernacular tradition of wood frame construction using local techniques and materials that developed in response to the climate, land conditions, and culture of the region.
- Homes and commercial establishments that promote an active relationship to the street: Stores and other commercial buildings were generally located on corner lots, where they could maximize their street exposure, and are typically located directly on the street right-of-way line. Homes were typically set back only a minimal distance, generally in the range of 10 feet or less. Front porches and front doors facing the street are a nearly universal feature. The rear portion of the lot was devoted to yard but often had smaller outbuildings or accessory buildings located near the rear lot line.

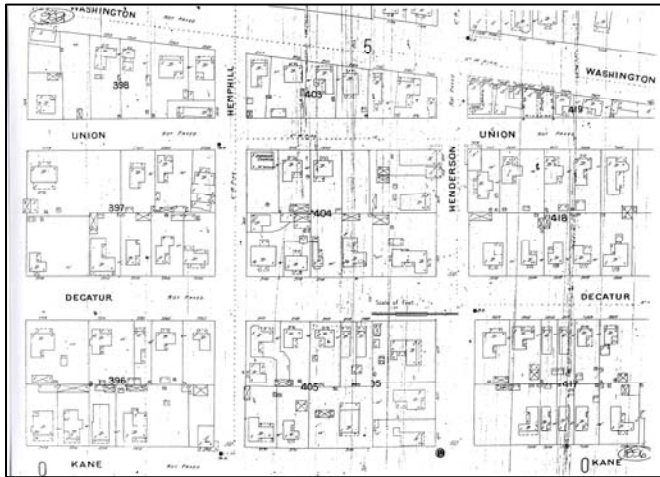

Figure I-1. A portion of the Sanborn Fire Insurance Map of 1896 showing a portion of Old Sixth Ward.

These characteristics are clearly indicated by maps of the time. Some of the old Sanborn Fire Insurance Maps dating from the 1890s and 1900s are still available; Figure I.1 shows a portion of one of these maps from an area within the current Old Sixth Ward Protected Historic District boundary.

In defining how new development can be introduced into this existing fabric in an appropriate and compatible manner, it may be helpful to begin by considering an example that would be clearly inappropriate. Figure I.2 depicts several lots along a typical street within the District. The two lots on the left represent historic cottages of types commonly seen in the District; the lot on the right illustrates a new development of a type that is becoming increasingly common in infill situations. The new construction shown here are two townhomes occupying a single lot. The front of the units is dominated by garage doors and driveways. In order to maximize living space, the living areas are usually located one level above grade, with bedrooms occupying a third level. This image illustrates several factors that contribute to the incompatibility of this development:

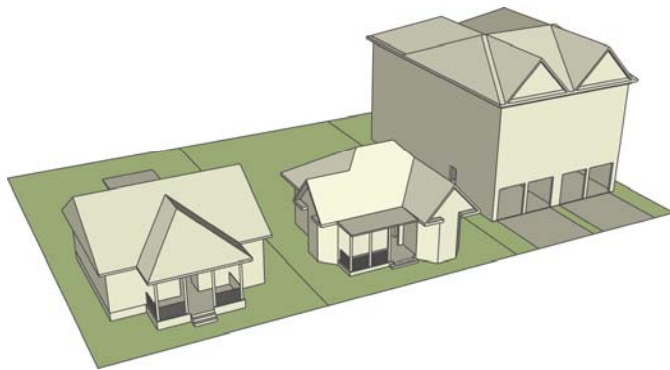

Figure I-2. An inappropriate example of massing.

- Disparity in scale and massing. The new construction is considerably taller than the adjacent buildings and occupies a much greater portion of the site.
- The disposition of parking and garages makes them the most dominant feature of the street frontage, in marked contrast to the more people-friendly front porch.

It should be stated that the intent of these Guidelines is not to stifle development in the District, but rather to provide for a range of options that integrate contemporary desires and expectations with the historic fabric in a mutually beneficial manner.

## B. Administrative Provisions

1. Administration. The provisions of these guidelines shall be administered and enforced by the Planning and Development Department. The Houston Archaeological and Historic Commission is the responsible approval authority for a Certificate of Appropriateness.
2. Applicable Regulations. These guidelines are a supplement to the provisions of Article VI, Historic Preservation, of Chapter 33 of the City of Houston Code of Ordinances.
  - a. These guidelines are specifically intended to clarify and illustrate the criteria for issuance of a Certificate of Appropriateness enumerated in Sections 33-240 through 33-242 of the Houston Code. In general, these criteria require that alterations to historic properties preserve the distinguishing qualities, and that new construction be compatible with historic structures on the blockface and facing blockface(s) in terms of setbacks, exterior features, and proportions.
  - b. Other City Ordinances also have bearing on development within the District, including, but not limited to:
    - i. Chapter 42, Subdivisions, Developments and Platting
    - ii. Chapter 26, Off-street Parking and Loading
  - c. Nothing in these guidelines or in other applicable regulations shall be construed to require a specific architectural style in the District.

## C. Language Conventions

1. Provisions activated by certain auxiliary verbs are to be read as follows:
  - a. *Shall* indicates a mandatory provision.
  - b. *Should* indicates a recommended provision.
  - c. *May* indicates an optional provision.
2. Certain terms may be abbreviated as follows:
  - a. *Director* means the Director of the Department of Planning and Development.
  - b. *District* means the Old Sixth Ward Protected Historic District.
  - c. *HAHC* means the Houston Archaeological and Historical Commission.
  - d. *Houston Code* means the City of Houston Code of Ordinances.

## **II. How to Use these Design Guidelines**

These Design Guidelines apply to all property located within the Old Sixth Ward Protected Historic District. Property within the District is classified as to whether it is a contributing structure, a potentially contributing structure, a non-contributing structure, or a vacant lot. Determining what type of work may be done within the District first requires classifying the proposed project according to the following criteria.

### **A. Is your property located inside the Old Sixth Ward Protected Historic District?**

Refer to Figure II.1 for a map of the Old Sixth Ward Protected Historic District. All property within the boundary indicated is subject to these Guidelines. Note that all property within the District has been classified as follows:

Contributing means a structure or site that reinforces the cultural, architectural, or historical significance of the District.

Potentially Contributing means a structure or site with incompatible alterations or deteriorating conditions that, if reversed, would reinforce the cultural, architectural, or historical significance of the District.

Non-contributing means a structure or site that does not reinforce the cultural, architectural, or historical significance of the District.

Vacant Lot is any property that has no existing building or structure, and is available for new construction.

This map reflects an accurate classification of the property as of March, 2007.

Once you have located your property and determined its classification, proceed to Item B below.

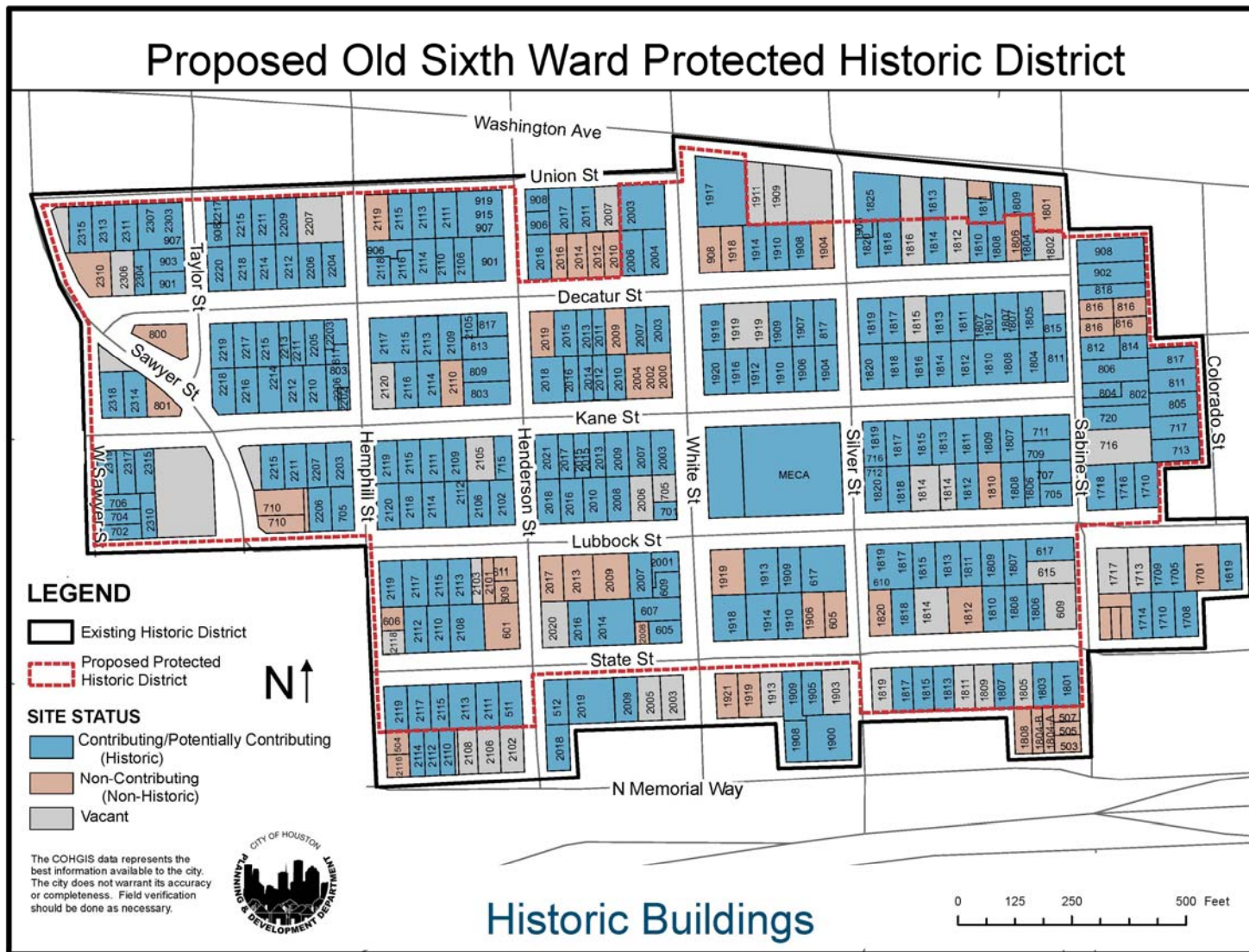

Figure II-I. Overall plan of the Old Sixth Ward Protected Historic District.



## B. What is the scope of your project?

These Design Guidelines define the relevant criteria for obtaining a Certificate of Appropriateness based on the property classification.

Refer to Figure II-2 for a table that correlates the classification of the property with the general type of construction that may be undertaken. The types of projects are classified as follows:

**Demolition** means an act or process that destroys in whole or in part any building, structure, object, or site.

**Alteration** means any change to the exterior of a building, structure, object, or site. Alteration shall include, but is not limited to, changing to a different kind, type, or size of roofing or siding materials; changing, eliminating, or adding exterior doors, door frames, windows, window frames, shutters, fences, railings, columns, beams, walls, porches, steps, porte-cocheres, balconies, or ornamentation; or the dismantling, moving, or removing of any exterior feature. Alteration does not include ordinary maintenance and repair.

**Rehabilitation** means the act or process of returning a building, structure, object, or site to a state of utility that makes possible an efficient contemporary use while preserving those portions or exterior features that are historically, architecturally, and culturally significant.

**Restoration** means the act or process of accurately recovering the form and details of a building, structure, object, or site and its setting as it appeared at a particular period of time by means of the removal of later work or by the replacement of missing earlier work or both.

**Relocation** means any change in the location of a building, structure, or object.

**New Construction** means any new building, structure, or object that occupies previously open land. A detached outbuilding on a site containing existing buildings or structures is considered new construction; attached construction or additions are considered alterations. Any construction on a vacant lot is considered new construction.

The field where the property classification and the project type intersect indicates whether that particular type of project is permitted, and also indicates which sections of the design guidelines apply. For example, an alteration project on a contributing property would be subject to Section III-B of these guidelines.

	<b>Demolition</b>	<b>Alteration or Rehabilitation</b>	<b>Restoration</b>	<b>Relocation</b>	<b>New Construction</b>
Contributing Structure	No	Yes (IV,V)	Yes (VI)	Economic Hardship Only	N/A
Potentially Contributing Structure	No	Yes (IV,V)	Yes (VI)	Economic Hardship Only	N/A
Non-contributing Structure	Yes	Yes (IV,V)	N/A	Yes	Yes (IV,V)
Vacant Lot	N/A	N/A	N/A	N/A	Yes (IV,V)

*Figure II-2. Table of Treatments and Applicable Regulations*

The table above correlates the types of treatment that may be undertaken depending on the classification of the building or structure, and refers the user to the appropriate sections of these guidelines.

For example, new construction, where permitted, is subject to the regulations in Sections IV and V. A restoration project is subject to the regulations in Section VI.

Section IV covers site development standards.

Section V covers building elements and details.

Section VI covers historic restoration.

### III. Construction Treatments

#### A. Demolition

1. Scope: These guidelines pertain to all contributing or potentially contributing structures located within the Old Sixth Ward Protected Historic District.
2. Contributing or potentially contributing structures shall not be demolished, unless they are deemed to be an imminent danger or unless economic hardship can be demonstrated. Refer to the relevant sections in Chapter 33 of the Houston Code, specifically to Section 33-247.
3. Section 33-247 of the Houston Code is reproduced below for convenience.

***Sec. 33-247. Same--Demolition of landmark, protected landmark, contributing structure, potentially contributing structure or within archaeological site.***

*(a) The issuance of a certificate of appropriateness for the demolition of a landmark, a protected landmark, a contributing structure or a potentially contributing structure or for demolition of a building, structure or object on or in an archaeological site shall be subject to the establishment by the applicant of an unreasonable economic hardship or the establishment of an unusual and compelling circumstance.*

- (1) Determination of an unreasonable economic hardship shall be based upon the following criteria:
  - a. That the property is incapable of earning a reasonable return, without regard to whether the return is the most profitable return, including without limitation, whether the costs of maintenance or improvement of the property exceed its fair market value;*
  - b. That the property cannot be adapted for any other use, whether by the current owner, by a purchaser or by a lessee, that would result in a reasonable return; and*
  - c. That efforts to find a purchaser or lessee interested in acquiring the property and preserving it have failed.**

*(2) With respect to a nonprofit organization, the city council recognizes that the determination of unreasonable economic hardship may depend on factors that are not applicable to an individual or a for-profit enterprise. To assist the HAHC in determining whether a nonprofit organization has met the criteria of item (1) above, the nonprofit organization may present and the HAHC may consider the following information:*

- a. *The amount paid for the property, the date of purchase, and the party from whom the property was purchased, including a description of the relationship, whether business or familial, if any, between the owner and the person from whom the property was purchased;*
  - b. *The assessed value of the land and improvements thereon according to the most recent assessment, or, if the property is exempt from local property taxes, a certified appraisal of the value of the property conducted by a qualified real estate appraiser;*
  - c. *Financial information for the previous two years, which shall include, at a minimum, the annual gross income of the nonprofit organization; itemized operating and maintenance expenses; real estate taxes or payments made in lieu of real property taxes, if any; annual debt service; and annual cash flow;*
  - d. *All appraisals obtained by the owner in connection with the acquisition, purchase, donation, or financing of the property, or during the ownership of the property;*
  - e. *All listings of the property for sale or rent, price asked and offers received, if any;*
  - f. *Any consideration by the owner of uses and adaptive reuses of the property;*
  - g. *Identification of reasonable reuses for the property within the context of the property and its location;*
  - h. *Rehabilitation cost estimates for the identified uses or reuses, including the basis of the cost estimates;*
  - i. *The current standard of building and maintenance costs for the performance of the mission or function of the nonprofit corporation, particularly in the Houston and Texas areas;*
  - j. *A comparison of the cost of performance of the mission or function of the nonprofit organization in the existing building and in a new building, and a comparison of the cost of rehabilitation of the existing building with the demolition of the existing building and the construction of a new building;*
  - k. *The impact of the reuse of the existing building on the financial condition of the nonprofit organization;*
  - l. *The impact of the reuse of the existing building on the organization's program, function or mission;*
  - m. *The additional cost, if any, attributable to the building of performing the nonprofit organization's function within the context of costs incurred by comparable organizations, particularly in the Houston area;*
  - n. *Grants received, applied for or available to maintain or improve the property;*
  - o. *The nonprofit organization's budget for the current and immediately past fiscal years; and*
  - p. *Consideration, if any, given by the nonprofit organization to relocation.*
- (3) *Determination of the existence of an unusual or compelling circumstance shall be based upon the following criteria:*
- a. *That current information does not support the historic or archaeological significance of the building, structure or object or its importance to the integrity of an historic district, if applicable;*
  - b. *Whether there are definite plans for reuse of the property if the proposed demolition is carried out and what effect such plans have on the architectural, cultural, historical or archaeological character of the surrounding area; and*
  - c. *Whether reasonable measures can be taken to save the building, structure or object from further deterioration, collapse, arson, vandalism or neglect.*

*If the HAHC determines that the applicant has demonstrated an unreasonable hardship or the existence of an unusual or compelling circumstance by a preponderance of credible evidence, the HAHC shall issue a certificate of appropriateness for demolition.*

*(b) If the HAHC does not issue a certificate of appropriateness for demolition pursuant to subsection (a), the planning official and the applicant shall explore alternatives to demolition. It shall be the duty of an applicant for a certificate of appropriateness for demolition to participate in good faith in a diligent effort to identify alternatives to demolition. The HAHC, the planning official and the applicant may consult with recognized historic preservation organizations and other civic groups, public agencies and interested citizens to determine the feasibility of:*

- (1) Public or other acquisition of the property, structure, building or object;*
- (2) Relocating one or more of the structures or features of the property if to do so would preserve its historic or architectural value; or*
- (3) Any other reasonable means of preserving the property, structure, building or object's historic or architectural value.*

*(Ord. No. 95-228, § 2, 3-1-95; Ord. No. 05-969, § 16, 8-17-05)*

## **B. Alteration or Rehabilitation**

1. Scope: These guidelines apply to the alteration or rehabilitation of any element of a contributing or potentially contributing structure that is visible from the exterior. Alterations are further categorized as follows:

- a. Minor Alteration. Changes to exterior materials and finishes, windows and doors, or exterior ornamentation that does not involve structural elements or changes to the building historical significance.
- b. Major Alteration. Alterations that involve changes to the roofline, structural framing, locations of exterior walls and porches, or selective demolition of certain building elements.
- c. Additions. Changes to the building envelope that involve clear and distinct expansions of the floor plan (as opposed to a bay window, dormer, or a chimney, which would be considered a major alteration). Additions shall be physically connected to the existing structure; if they are wholly detached and independent of the existing structure, they would be considered new construction.

2. Applicable Regulations. Depending on the category of alteration, the following sections of the guidelines apply:

- a. Minor Alteration. Since the change will not affect the majority of the building or structure, the changes should not deviate substantially from the established range of materials and finishes.

Refer to Section V, Building Elements and Details and Section VI, Historic Restoration.

- b. Major Alteration. Refer to Section V, Building Elements and Details.
- c. Additions. Refer to Section IV, Site Planning Standards and Section V, Building Elements and Details.

3. Section 33-241 of the Houston Code is reproduced below for convenience.

**Sec. 33-241. Same--Alteration, rehabilitation, restoration and construction.**

(a) *The HAHC shall issue a certificate of appropriateness for the alteration, rehabilitation, restoration or construction of an exterior feature of (i) any landmark, (ii) protected landmark, (iii) any building, structure or object in an historic district, or (iv) any building, structure or object that is part of an archaeological site, upon finding that the application satisfies the following criteria, as applicable:*

- (1) The proposed activity must retain and preserve the historical character of the property;*
- (2) The proposed activity must contribute to the continued availability of the property for a contemporary use;*
- (3) The proposed activity must recognize the building, structure, object or site as a product of its own time and avoid alterations that seek to create an earlier or later appearance;*
- (4) The proposed activity must preserve the distinguishing qualities or character of the building, structure, object or site and its environment;*
- (5) The proposed activity must maintain or replicate distinctive stylistic exterior features or examples of skilled craftsmanship that characterize the building, structure, object or site;*
- (6) New materials to be used for any exterior feature must be compatible with the materials being replaced in composition, design, texture and other visual qualities;*
- (7) The proposed replacement of missing exterior features, if any, should be based on accurate duplication of features, substantiated by available historical, physical or pictorial evidence, where that evidence is available, rather than on conjectural designs or the availability of different architectural elements from other structures;*

- (8) Proposed additions or alterations must be done in a manner that, if removed in the future, would leave unimpaired the essential form and integrity of the building, structure, object or site;*
- (9) The proposed design for alterations or construction must not destroy significant historical, architectural or cultural material and must be compatible with the size, scale, material and character of the property and the area in which it is located;*
- (10) The setback of any proposed construction or alteration must be compatible with existing setbacks along the blockface and facing blockface(s); and*
- (11) The proposed activity will comply with any applicable deed restrictions.*

*(b) In reviewing applications for certificates of appropriateness under this section, the HAHC shall also consider any elements of the proposed activity that may be necessary to enable the property to comply with any other applicable city ordinances or state or federal law so as to facilitate compliance with this ordinance and other applicable laws.*

*(Ord. No. 95-228, § 2, 3-1-95; Ord. No. 05-969, § 14, 8-17-05)*

### C. Restoration

1. Scope: Restoration is applicable to contributing or potentially contributing structures. Restoration involves careful attention to the historic integrity of the building or structure and its original materials and construction techniques.
2. Applicable Regulations: Refer to Section VI, Historic Restoration.

### D. Relocation

1. Scope: The relocation of any structure into the District or any contributing or potentially contributing structure out of the District shall require a Certificate of Appropriateness.
2. Relocation of a contributing or potentially contributing structure within the historic district or away from the historic district may be considered in cases when an economic hardship can be proven. Relocation is subject to the provisions of Sections 33-242 through 33-245 of the Houston Code.

### E. New Construction

1. Scope. Guidelines for new construction apply to any construction on a vacant lot or to any detached construction on an existing built lot.
2. New construction within the District shall be subject to the compatibility standards and design criteria established in these guidelines. Compatibility means that the new construction is consistent with historic structures in terms of

setbacks, exterior features, and scale. No specific architectural style is dictated by these guidelines, nor should any new construction replicate historic architecture.

3. Applicable Regulations: Refer to Section IV, Site Development Standards and Section V, Building Elements and Details.
4. Section 33-242 of the Houston Code is reproduced below for convenience.

***Sec. 33-242. Same--New construction in historic district.***

*The HAHC shall issue a certificate of appropriateness for new construction in an historic district upon finding that the application satisfies the following criteria:*

- (1) The new construction must be compatible with the setbacks along the blockface and facing blockface(s);*
- (2) The exterior features of new construction must be compatible with the exterior features of structures along the blockface or facing blockface(s); and*
- (3) The proportions of the new construction, including height, width, length and roofline, must be compatible with structures and objects along the blockface or facing blockface(s).*

*Nothing in the foregoing shall be construed to require or impose a single architectural style in any historic district.*

*(Ord. No. 95-228, § 2, 3-1-95)*



## IV. Site Development Standards

This Section is divided into two categories: Required Guidelines and Recommended Guidelines.

### Required Guidelines

#### A. Street Frontage

1. Intent: All construction should be compatible and primary façades should face the street as do the existing historic buildings. Primary entrances should also face the street.
2. Front porches are highly recommended on any new construction. Porches are one of the essential defining features of historic houses in the District.
  - a. Minimum recommended width: 50% of total width of building.
  - b. Minimum recommended depth: 6 feet.

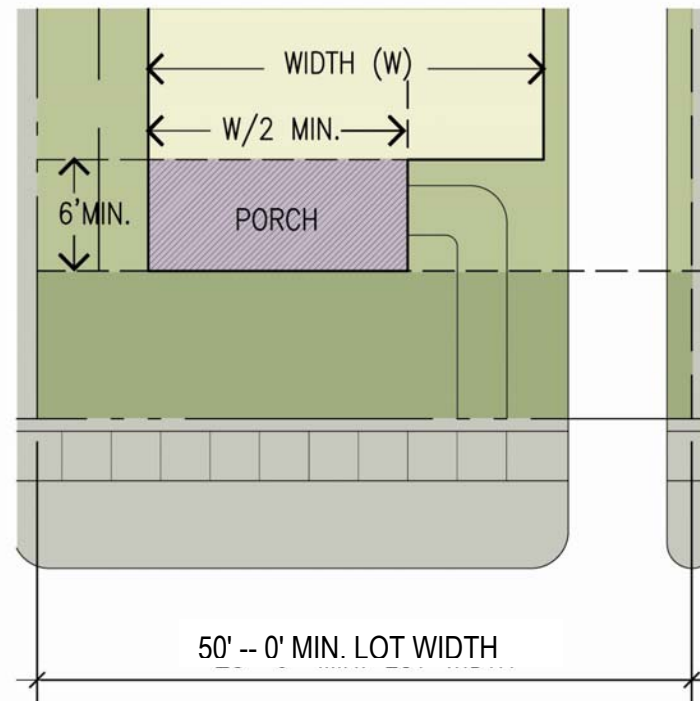

Figure IV-1. Minimum porch recommendations.

## B. Building Lines

1. Intent. The general rule for compatible building lines is to match the most frequently occurring building line on the blockface or facing blockface(s).
2. Whereas all building lines (i.e., front, rear, and sides) are important, matching the front building line condition, including a porch where applicable, is considered of primary importance.

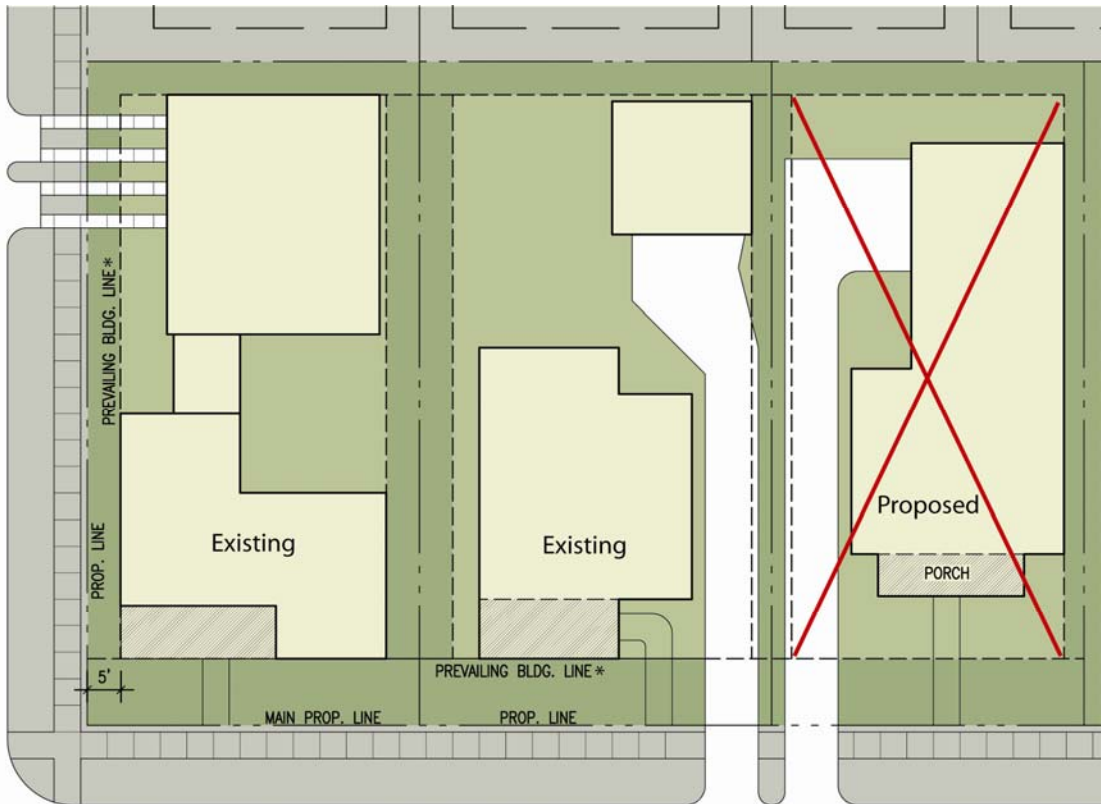

Figure IV-2. Building line requirements.

Note: Prevailing building line tends to be 10' on East and West streets and 5' on North and South streets.

### C. Parking

1. New construction shall provide off-street parking as required in the Houston Code.
2. Garages or covered carports shall be located on the rear half of the lot; driveways must be placed to the side of the dwelling for interior lots. Driveway material must be concrete, stone, brick pavers, or gravel.
3. Driveway access to the garage on interior lots is limited to a single driveway with a maximum width of 10 feet at any point within the front half of the lot.
4. On corner lots, garage access shall be from the side street.
5. Exception: On lots of insufficient width (generally 25 feet wide), a porous parking pad in compliance with City codes may be placed in front of the building for off-street parking. Variances may be granted for special circumstances.

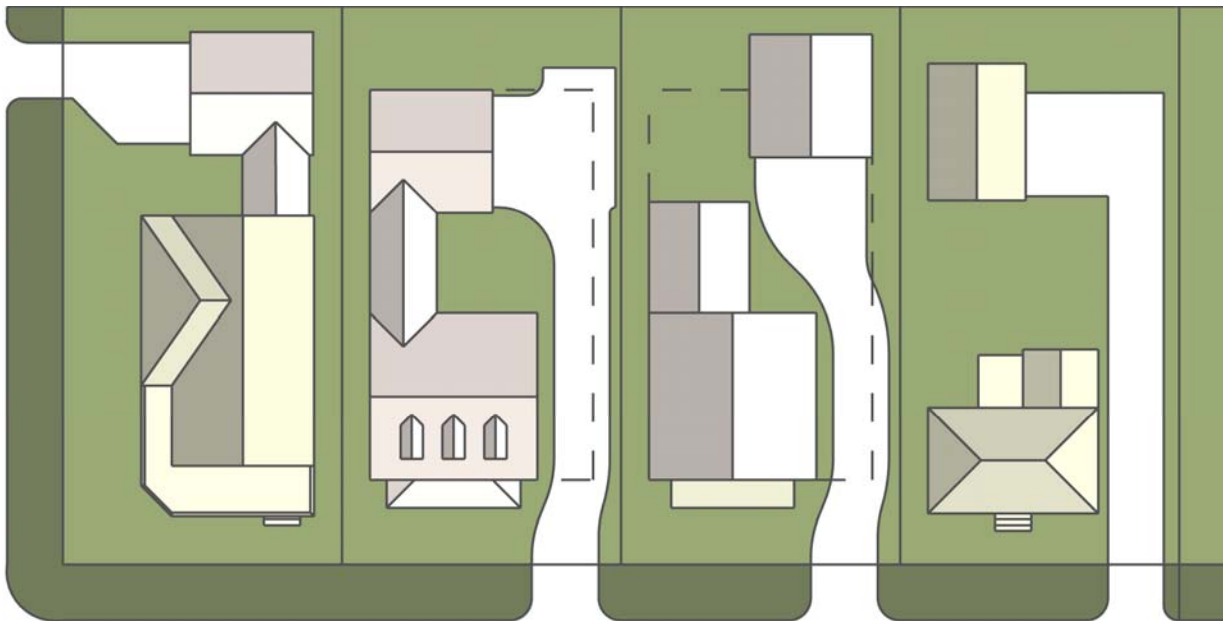

Figure IV-3. Appropriate configurations for garages and driveway access.

## D. Signage

While Old Sixth Ward is predominantly residential in character, there are a few small scale commercial buildings in the District. There are also instances of residential structures that have been converted to a small office or other commercial uses. The following provides a guideline to types of signs that would be considered appropriate.

1. General Provisions: Signage within the District should be designed and painted in a manner to respect the historic character of the buildings and the neighborhood. The signs should be:
  - a. Appropriate in size and scale.
  - b. Constructed of high quality materials and craftsmanship.
  - c. Located in a logical place on the building or in the front yard, and should not obstruct key elements or details of the building.
  - d. In a style that is compatible with the character of the services or merchandise.
  - e. (If lighted) Illuminated indirectly and using an external light source.
2. Address Numbers: All residential and commercial buildings are required by the Houston Code to identify their street address numerals. Address numerals should conform to the following guidelines:
  - a. Numerals should be displayed near the main entry and clearly visible from the street fronting the building.
  - b. Numerals may consist of individual characters or a decorative panel.
  - c. Numerals should be no more than 6 inches in height. Panels should be no more than 1 square foot in area.
3. Commercial Signage: These guidelines apply to on-premises signage for commercial buildings that are clearly commercial in nature: i.e., not converted residential structures. Signs are classified into the following types:
  - Building Signage
  - Sign Band
  - Bracket Signs
  - Window Signs
  - Monument and Pole Signs
  - Post Signs

Recommendations for specific sign types are as follows:

a. Building Signage: The developer of a building may give the building a name, or the major tenant of the building may place its name on the building, according to the following specifications:

1) Placement:

- (a) Sign should be placed near the top of the building.
- (b) Sign should be placed above upper floor windows.
- (c) Sign is to be mounted directly on the wall surface, and the background must be the building wall.
- (d) Sign must face a public street.
- (e) Signage may be placed on a maximum of two building sides.
- (f) Signs may be cut or carved.
- (g) No roof signs are permitted.

2) Dimensions:

- (a) A maximum of 20 square feet for each sign is permitted.
- (b) Lettering may be a maximum of 16".
- (c) Sign may include a logo, which will be counted toward total square feet.

3) Letter materials:

- (a) Sign may be metal, stone, wood, paint, carved, or plaster. No plastic letters are permitted.

4) Lighting:

- (a) Front-lit signs (illuminated by an external light source) are acceptable. No backlit or channel cut lighting permitted.

5) Other provisions:

- (a) No neon signs are permitted.
- (b) Signs shall be static; no rotating, electronic, or digital signs are appropriate.
- (c) Inclusion of a numerical date is optional.

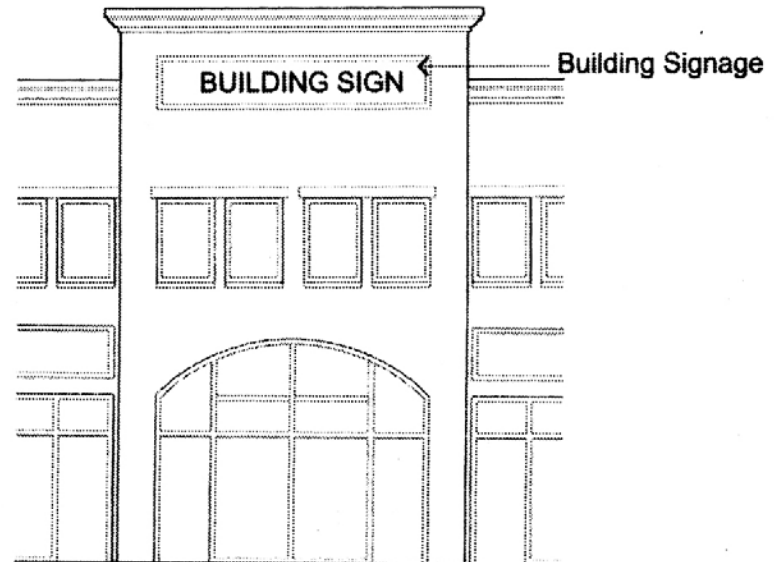

b. Sign Band. This type of sign is intended primarily for retail uses at street level to draw the attention of pedestrians and drivers.

1) Placement:

- (a) Sign should be mounted on the building face between the first and second floor window openings.
- (b) Sign should be integrated with the composition of the façade.
- (c) Background may be the building wall or “backboard”.
- (d) Profile of the sign should be essentially flush.
- (e) Bottom edge of sign should be located a minimum of 10’ above sidewalk.

2) Dimensions:

- (a) Backboard and overall band width is limited to 60% of bay width.
- (b) Backboard may have a maximum height of 24”.
- (c) Letters may have a maximum height of 18”.

3) Letter or backboard materials:

- (a) Sign may be metal, stone, wood, paint, carved, plaster, or plastic; cabinet signs are not permitted.

4) Lighting:

- (a) Front-lit signs (illuminated by an external light source) are acceptable.

5) Other provisions:

- (a) No neon signs are permitted. Consistency of the sign bands in a single building is recommended.



c. Bracket Signs. These may be used in place of a sign band, or in addition to a sign band if located in an arcade or if the bracket sign is not in conflict with the sign band. Bracket signs may include symbols such as barber poles.

1) Placement:

- (a) Sign must be perpendicular to the principal building façade.
- (b) Sign may be held by brackets, cantilevered, or suspended under a canopy.
- (c) Sign placement must allow a minimum sidewalk height clearance of 8'.
- (d) For residential buildings converted to commercial use, a sign panel hanging from the porch beam is acceptable.

2) Dimensions:

- (a) Sign may be a maximum of 6 square feet.
- (b) Bracketed signs may project a maximum of 48" from the building face but may not project over a public right-of-way.
- (c) Double-sided signs are permitted.
- (d) Letters may have a maximum height of 10".
- (e) Logos or artwork may be a maximum of 18" in any dimension.

3) Materials:

- (a) Sign may be metal and/or wood.

4) Lighting:

- (a) Externally projected lighting is permitted.

5) Design:

- (a) A logo may be included on the face of the sign.

6) Other provisions:

- (a) No neon signs are permitted.
- (b) Any signage that is approved as appropriate but encroaches over a public right-of-way must obtain a license agreement from the Finance & Administration department.

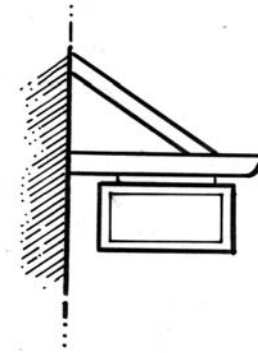

d. Window Signs. These signs are intended for the pedestrian. They include applied graphics such as name, hours of operation, telephone numbers, and street numbers. “Open/closed” hanging signs are acceptable.

1) Placement:

- (a) Signs may be placed on storefront windows and doors.
- (b) Signs may be applied to the interior surface of glass only.
- (c) Signs may not substantially obscure visibility through the window; signage should be located in the upper third of the window.

2) Dimensions:

- (a) Window graphics are limited to 5% of total glass area of the storefront.
- (b) Lettering size may be a maximum of 6”.

3) Letter Materials:

- (a) Signs may be vinyl, gold leaf, painted, or stick-on plastic.

4) Lighting:

- (a) Lighting of window signs is not permitted.





- e. Monument and Pole Signs. These types of signs are not appropriate for use within the District.

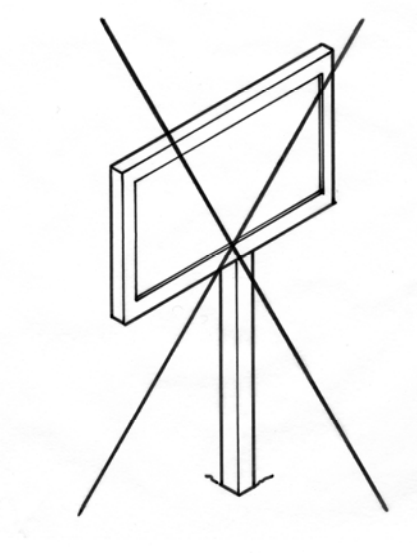
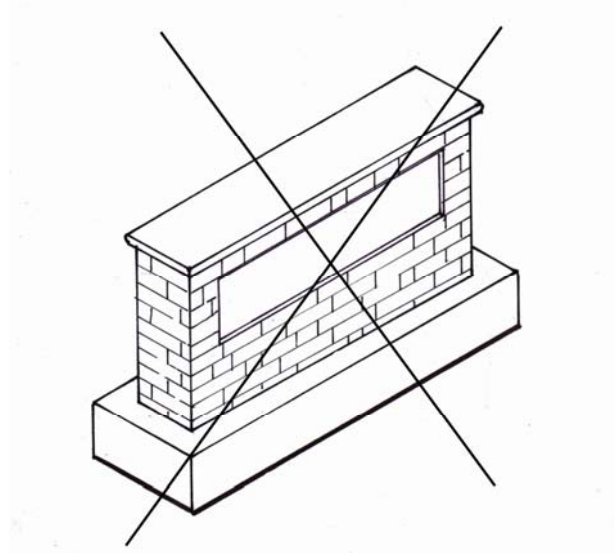

Other inappropriate commercial sign types include:

- 1) Large or illuminated signs behind the glass storefront that advertise on a permanent basis.
- 2) Applied window signs, such as cardboard panels.
- 3) Trailer signs.

f. Post Signs. These signs are appropriate for residential structures that have been converted to commercial use. These are typically small and understated signs meant to be relatively unobtrusive in a neighborhood setting.

1) Placement:

- (a) Sign should be perpendicular to the ground, near the entrance to the property.
- (b) Sign may be parallel or perpendicular to the front façade.
- (c) Sign must be on the property and may not encroach into the right-of-way.

2) Configuration:

- (a) Sign may be a double post with framed panel or an offset single post with bracketed or suspended panel.
- (b) Double-sided signs are acceptable.
- (c) A single post with centered panel is not recommended.
- (d) Sign must be essentially two-dimensional. Small structures or kiosk-type designs are not appropriate.

3) Dimensions:

- (a) Sign panel should be a maximum of 6 square feet;
- (b) Overall sign should be a maximum height of 4 feet above grade.

4) Materials:

- (a) Sign may be metal and/or wood.

5) Lighting:

- (a) Post signs should not be illuminated.

6) Design:

- (a) Sign panel is limited to a two-dimensional graphic layout.
- (b) A logo may be included on the face of the sign.

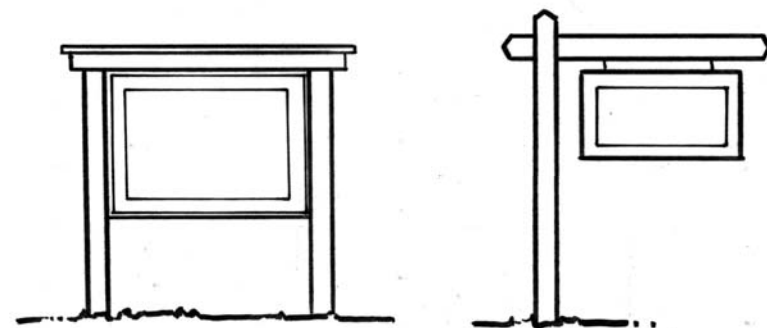

*Recommended*

*Recommended*

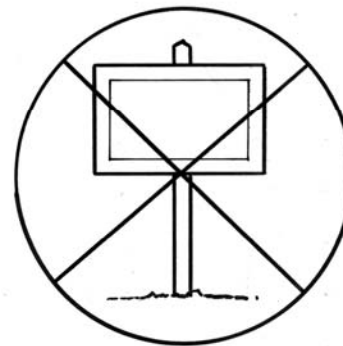

*Not recommended*

4. Temporary Signage. Temporary signage may remain in place for two (2) months. Acceptable temporary signage types include:

- Seasonal signs
- Promotional and sale signs
- Announcement signs
- Event signs
- Real estate signs
- Political campaign signs
- Future or ongoing construction

Pennants and banners are not permitted.

- a) Seasonal, promotional, sale, announcement, and event signs:
  - 1) Retail uses may advertise special promotions and sales.
  - 2) Signage is limited to the display windows and must be located inside the glass.
  - 3) Temporary sandwich boards are permitted.
- b) Real estate signs:
  - 1) On residential properties, real estate signs are limited to the standard two-faced ground signs of no more than 3 square feet in area.
  - 2) No more than one rider (i.e., “sale pending” or similar message) may be added;
  - 3) Real estate signs must be removed promptly once the sale is closed.

- c) Political signs:
  - 1) Political signs must be located on private property.
  - 2) Yard signs and window signs may be no larger than 2 ½ square feet in area.
  - 3) Large banners and billboards are not permitted.
  - 4) Political signs must be removed within seven (7) days after the election.
- d) Construction signs.
  - 1) Construction signs that primarily advertise the builder must be no larger than 6 square feet in area.
  - 2) Larger commercial or civic projects that include a professional rendering of the project may use signs as large as 4 feet by 8 feet. The illustration must occupy at least 40% of the total area, with the balance reserved for information about the architect, contractor, etc.
  - 3) Construction signs must be removed promptly at the end of construction.

## **Recommended Guidelines**

### **A. Service and Utilities**

1. General: Service elements should be located at the rear of the building, preferably so that they are not visible from any public street. Service elements should not be located within any street-fronting yard setback. Service elements visible from a public street shall be screened by an opaque wall or fence of sufficient height to completely obscure the equipment. A landscape screen, such as a hedge, may be used, provided that it is opaque and maintained at the appropriate height.
2. Recommendations for Specific Elements:
  - a. Mechanical Equipment: Certain mechanical equipment items may be located on the roof, provided that they are screened from view by an opaque screen compatible with the architecture of the building. The screen shall be of sufficient height to completely obscure the equipment when viewed from any point in a public right-of-way.
  - b. Plumbing vents, roof attic vents, electrical, cable/telephone service lines, and satellite dishes should not be located on any roof plane facing the lot frontage.

### **B. Landscaping**

1. Landscaping within the front yard and the street right-of-way is intended primarily to enhance the visual experience for the pedestrian and to provide a sense of continuity of design. In general, the intent is not to screen the buildings from view, but to provide a complementary contrast in texture and color.
2. Front yard landscaping should play a supporting role and help to accent and enhance the architecture. The screening of the building face with planting is neither appropriate nor desirable.
3. Landscaping within private areas of the lot, generally in side and rear yards, is afforded a much greater freedom, provided that the overall landscape provisions meet the minimum requirements of Chapter 33 of the Houston Code.

### C. Fencing and Screen Walls.

Two types of fencing conditions are recommended:

1. Front yard fencing (applies also to side streets on corner lots):
  - a. Type: This low, mostly open fencing is intended primarily to define the front yard area, rather than to provide any visual screen or security. Wood picket fencing and ornamental steel rail and picket fencing are recommended fence types.
  - b. Height: The body of the fence may be a maximum of 60 inches high. Posts, which may include decorative finials, may be a maximum of 66 inches high.
  - c. Placement: Fencing may be placed along any street frontage and may return to the building face or to intersect with privacy fencing at appropriate locations.
2. Rear yard and privacy fencing.
  - a. Type: This mostly opaque fencing is intended to provide a visual screen or barrier.
  - b. Height: Fence may be a maximum of 6 feet high.
  - c. Placement: Fencing may be used to enclose rear yards and to screen unsightly elements, such as mechanical equipment, dumpsters, etc. Privacy fences may also enclose side yards, provided that they are placed at least 10 feet from the front building line.

3. Materials *not* recommended for fencing or screen walls include:

- Chain link, with or without inserts
- Corrugated or formed metal panels
- Plain concrete masonry
- Concrete or pre-cast concrete
- Barbed wire or razor wire



Figure IV-5. Examples of front yard fencing that meet the guidelines.

## V. Building Elements and Details

### A. Characteristics

The historic character of the District derives from a building tradition that was based on wood framing and carpentry. Brick construction is uncommon, although it does occur. When found, it is typically limited to commercial or civic buildings or the larger, more elaborate houses. The typical wood-framed examples are characterized by:

- Raised pier and beam foundations.
- Front porches, which often run along the entire front of the building.
- Relatively slender porch columns, which may range from simple square posts to turned columns.
- Narrow, vertically proportioned windows, with horizontal lintels. (Arched openings are generally not used, unless constructed of brick.)
- Exterior walls of horizontal lap siding in a variety of profiles.
- Pitched roofs, usually with end gables. Exposed rafter tails are fairly common.

With few exceptions, the historic structures in the District do not represent an established or defined style such as Queen Anne or Victorian. Most of the structures are fairly modest buildings that were constructed by carpenters and craftsmen working in an informal, vernacular tradition. Details may have been copied from other buildings or from publications, without regard to a strict adherence to style. These guidelines are not intended to impose any particular style, only to clarify what qualifies as compatible construction.



*Figure V-1. This house displays many of the defining characteristics of the historic houses in Old Sixth Ward.*

It is more useful to think of the construction techniques in the District as ranging between the vernacular and the refined. The vernacular is typically done in the most simple, straightforward manner, using widely available materials, common techniques, and relatively little ornament. On the other hand, a client with greater means may have insisted on a more refined level of detail, and an additional level of applied ornament. This could involve such enhancements as turned posts instead of square posts, more elaborate balusters and trim work, and decorative fretwork.

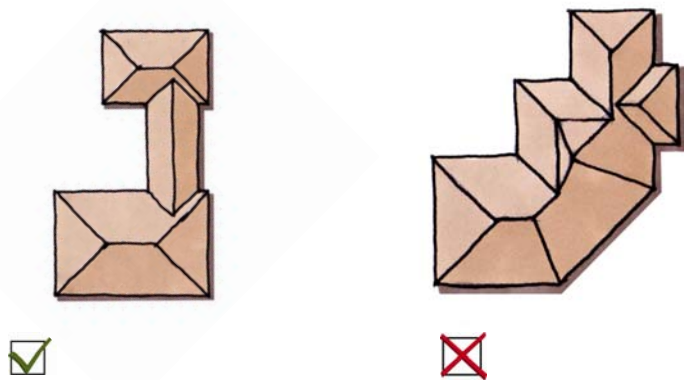

Figure V-2. Appropriate massing combines simple forms, preferably with a functional basis for differentiation.

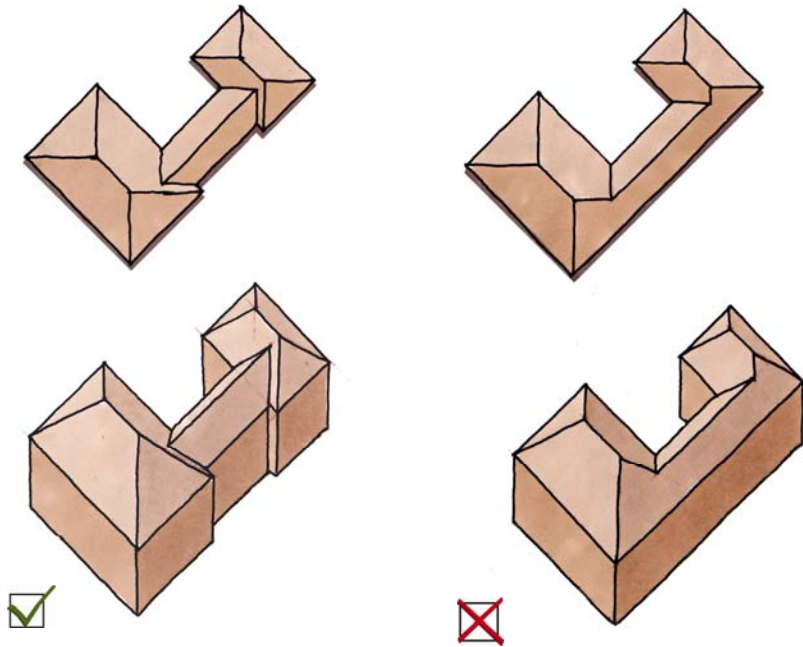

Figure V-3. Separate volumes should be articulated for clarity.

## B. General Standards for New Construction.

These standards are meant to define and illustrate compatible construction. As stated in Section 33-242, a structure must be compatible in terms of setbacks, as further clarified in Section IV of these Guidelines. It also must be compatible in terms of exterior features, scale, roofline, and proportions. Examples of compatible new construction are illustrated in this document (Section D: Key Construction Details).

### 1. Exterior Features:

- a. Buildings shall be composed of simple, rectilinear volumes, or combinations of simple volumes when the resulting footprint serves a meaningful purpose, such as defining an exterior courtyard or a focal element on a front façade.
- b. When combining multiple volumes to create a more complex envelope, each volume should be clearly articulated.
- c. The use of angles other than right angles should be limited to subordinate accent elements such as bay windows.

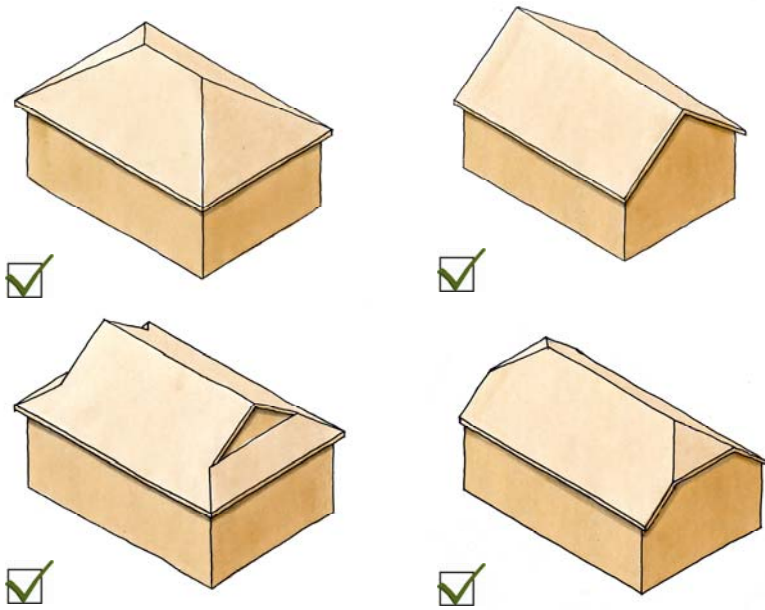

Figure V-4. Appropriate roof forms, clockwise from top left, include hip, gable, truncated gable, and gable-on-hip.

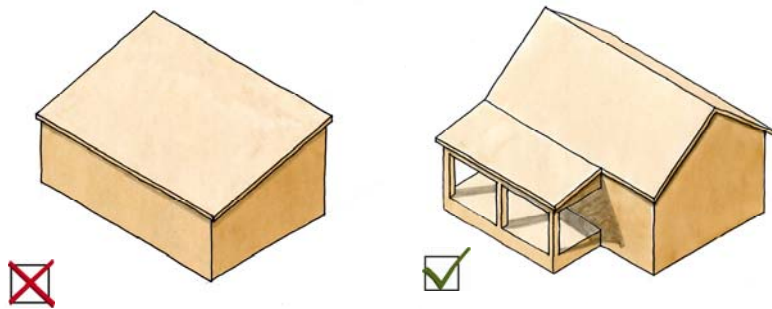
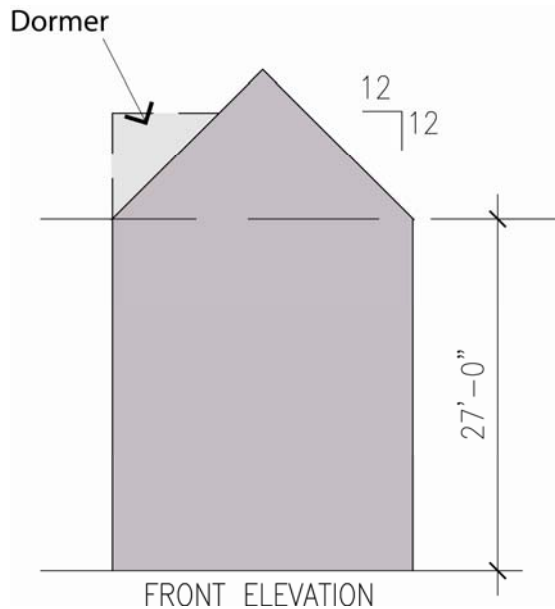

Figure V-5. Monopitch or shed roofs should be avoided unless part of a subordinate element.

## 2. Roof Forms.

- a. Residential buildings should have pitched roofs of simple profiles, generally limited to gabled roofs, hipped roofs, or some combination thereof. Hybrid designs such as a gable-on-hip roof or truncated gable are also acceptable.
- b. Monopitch roofs should be avoided but are permissible when part of a subordinate element or framing into a vertical element.
- c. Roof pitches should be in the range of 6-on-12 to 12-on-12.
- d. Flat roofs are permissible only on storefront, commercial buildings. Flat roofs shall be defined by a parapet along any street-facing elevation.



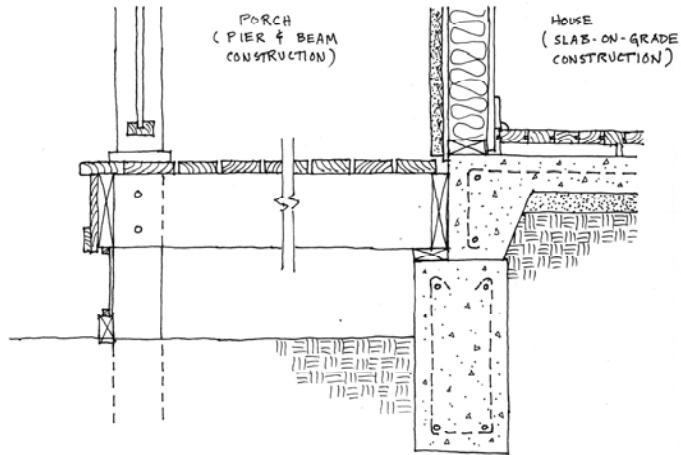

*Figure V-6. Permissible building envelope. Dormers comprising less than 10% of the footprint area may project above the height envelope.*

### 3. Height:

An appropriate building height, as with many other characteristics in the District, is determined by the condition existing on the blockface or facing blockface(s). While the specific conditions may vary, the following provisions may be used as a general guideline.

- a. Building height in the District should generally not exceed 2 stories (approximately 27 feet) at the top of the eave board at the side and rear building lines. The height may be increased by one foot for every foot of distance inside of the building line. Occupied space is permitted within the roof structure, provided that the overall building form fits within the recommended envelope defined here.
- b. Dormers comprising less than 10% of the building's footprint area may project above this recommended envelope.



*Figure V-7. A combination foundation with a porch on pier and beam and the main structure on slab.*

#### 4. Special Elements:

- a. Front porches are highly recommended for all residential structures. Porches should extend a recommended minimum of 50% of the overall width of the structure, and should be at least 6 feet deep.
- b. Raised foundations. The historic homes in the District were generally built on raised pier and beam foundations, in the typical manner of the time. The finished floor height is usually at least two (2) feet above grade. While the use of pier and beam foundation is not required for new construction, slab on grade must be elevated and detailed to resemble a raised foundation.

#### 5. Accessory Buildings:

- a. Buildings that are subordinate to the principal building on the site shall not be placed on the primary street frontage. Accessory buildings shall be located on the rear half of the lot.
- b. Accessory buildings shall be architecturally compatible with the principal building.

### **C. Major Alterations and Additions**

1. **Applicability:** Any alteration to an existing historic structure that changes the structure or roofline or adds to the footprint of the structure shall comply with the provisions of this Section. Refer to Section III-B for the definitions of Major Alterations and Additions.
2. **Intent:** This Section addresses significant modifications to existing contributing and potentially contributing structures. Such changes are permitted subject to the requirements of this section, which are intended to define the extent of modifications permitted while maintaining the integrity and character of the existing building or structure.
3. **Guiding Principles:**
  - a. Additions should generally be confined to the rear portion of an existing building and should leave the existing street frontage essentially unchanged.
  - b. Vertical additions (that is, adding a second or third story to an existing footprint) are generally more difficult to achieve in an aesthetically convincing manner.

### **D. Key Construction Details.**

1. **Foundations:** Foundations should be designed so that the finished floor surface is at least 18 inches above prevailing grade. The traditional method, used widely throughout the District, is a raised pier and beam foundation. Conventional slab on grade foundations may also be used but should be elevated on slightly deeper perimeter-grade beams to achieve a similar effect. Concrete foundations should be detailed to express a clear distinction between the foundation material and the wall material. This is generally accomplished by transition elements such as a horizontal frieze board or water table.

Porch foundations should be detailed as pier and beam foundations. A combination system with a concrete slab for interior spaces and a pier and beam foundation for the porch areas can be readily achieved.

Foundation piers shall be faced with monochromatic (one color) brick or stucco.

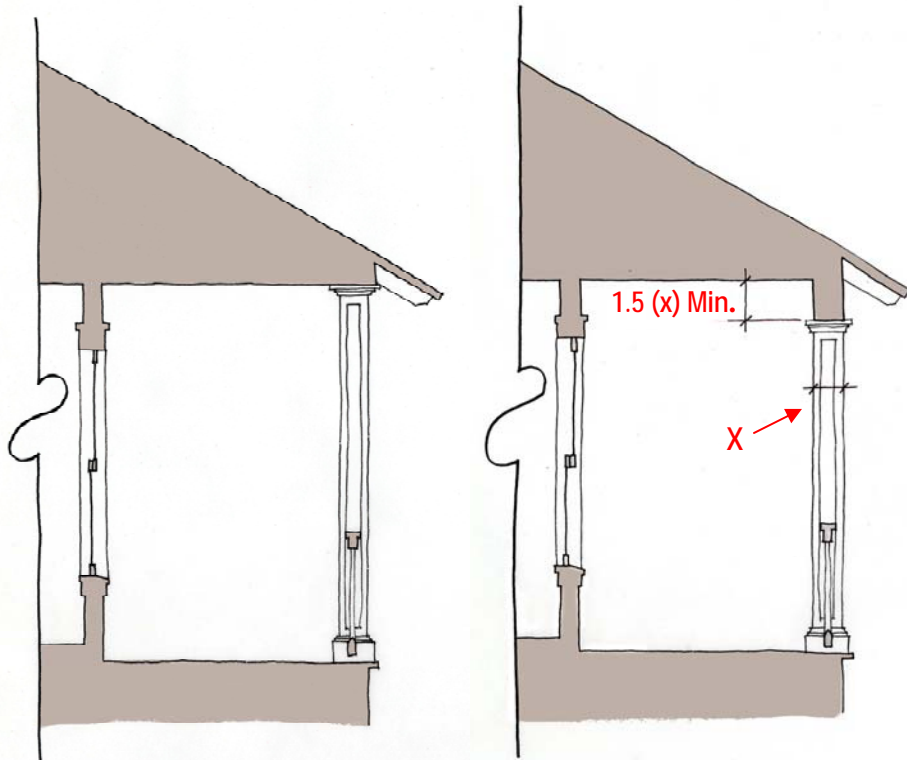

 Avoid porch framing with no visible beam dropped below the roof/soffit line.

 A well proportioned porch should have a substantial beam spanning over the tops of columns, separate and distinct from the roof eave.

Figure V-8. Porch beams.

2. Porches: Front porches are an essential characteristic of the Old Sixth Ward house and are highly recommended for compatible new construction. Porches should be a minimum of 6 feet deep with 8 feet of headroom. It is recommended that porches are at least half as wide as the overall width of the structure.

- a. Columns: Porches should be defined by a series of similar columns spaced in a regular manner. In cases where there is an unusually long colonnade (a row of columns), the corner columns may be differentiated, generally by being more massive.
- b. Porch Beam: The porch beam is the horizontal element spanning across the tops of the columns. A properly proportioned porch beam is important to achieving a convincing porch design. It should be a clearly expressed element dropping below and distinct from any soffit or eave. The porch beam should be at least as deep as the width of a typical column, and preferably about 1.5 to 2 times the column width.
- c. Guardrails are required for any porch that is more than 30 inches above the adjacent grade. Guardrails shall consist of a series of repetitive vertical balusters spanning between a lower rail and a top guardrail. They should be fairly open, generally with at least 50% open area. Avoid solid panels or “pony walls.”

Baluster designs may vary greatly, ranging from simple 2x2 square pickets to turned posts. Flat boards cut into a decorative, repetitive pattern are also acceptable.

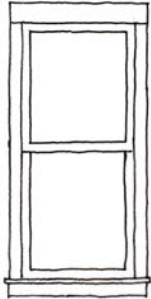

*Window trim should articulate a sill element, as well as a header that is deeper than the jambs.*

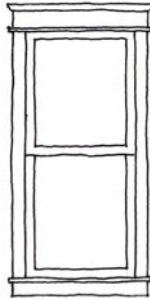

*This same principle can be rendered with more ornate moldings in a more decorative or more formal style.*

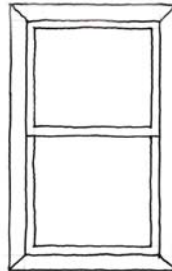

*Do not use mitered boards of the same width to trim an opening.*

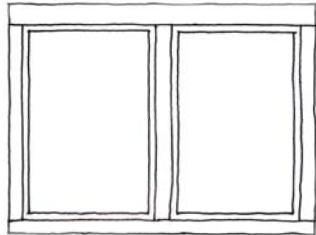

*Expansive views and greater amounts of glazing may be achieved by mulling together several vertical windows.*

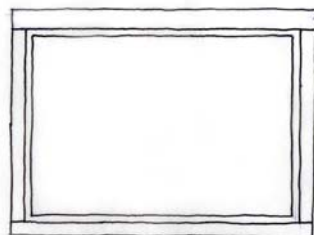

*Windows shall be vertically proportioned, that is, taller than they are wide.*

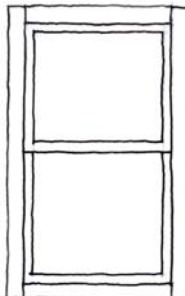

*The horizontal trim elements should dominate at corners, so that the jambs appear to rest on the sill, and the header appears to rest on the jambs.*

### 3. Windows:

- a. Proportion: Any single window should be square or vertically proportioned (i.e., taller than it is wide). Several windows may be grouped together for wider arrangements.
- b. Types: Windows should be of wood or clad wood profiles. Vinyl and fiberglass profiles that resemble wood may also be used. Residential aluminum windows should be avoided. Operable windows should be double hung, single hung, or casement types.

Divided lights, if used, should be true divided lights with working muntins (strips of wood that separate and hold the panes of glass) rather than snap-in false muntins.

- c. Specialty Windows: Specialty windows include such shapes as round, oval, or fan. They shall be used sparingly and generally only for accent purposes. They shall be of similar materials and construction as the other windows and compatible with the architectural style of the house.
- d. Shutters: Shutters should be real, operable units and (whether operable or decorative) should be correctly proportioned to the window opening (i.e., with a width equal to one half the opening width). Shutters should not be used on double or triple openings. Rolling shutters are not recommended.

Figure V-9. Window and trim configurations.

4. Doors:

- a. Entry doors facing the street should feature a transom window above the door.
- b. Sidelights are desirable for entry doors and should be placed on each side of the door.

5. Trim Work:

- a. Trim work should be compatible with the major construction materials. Wood or Hardiboard trim should be used with wood siding. Stucco may have relief trim of a like material or may be treated with simple, unarticulated transitions.
- b. Particular attention should be paid to trim work around window and door openings. Properly detailed trim around openings should mimic a structure: for example, the jambs should appear to rest on the sill and to support the lintel. The lintel should be deeper than the jamb width. Avoid mitered corners.

6. Dormers:

- a. A dormer should be considered as part of the roof rather than trying to mimic the wall below. Dormers are generally used to provide windows for an upper story that is built within the roof form; the window is the principal reason for the dormer. It should thus be expressed as framing around a window, and not a short piece of wall with a window opening. The key detail is the jamb, which should be expressed as a single piece of trim, with no siding showing.
- b. A dormer should be proportioned similarly to a window; that is, substantially taller than it is wide. Dormers may be wider if they frame around multiple windows, each properly proportioned and grouped with appropriate framing and spacing.
- c. Half dormers (sometimes called wall dormers) are generally used only in masonry or stucco construction and are a way of introducing a heavy wall material as a dormer finish that would otherwise look awkward and unnatural when supported by a roof. The wall element should form a parapet, so that the roof and the wall are clearly expressed as distinct elements.

7. Eaves:

a. Roof overhangs are recommended. A vernacular treatment seen widely in the District is to simply leave the roof rafters exposed beyond the wall line. This can be done with a straight cut, a plumb cut, or a decorative shape.

b. If a flat soffit is desired, the eave should have a horizontal return at all gable ends.



*Vernacular treatment simply extends the framing beyond the wall.*



*If a flat soffit is desired, the gable end should be finished with a horizontal return.*

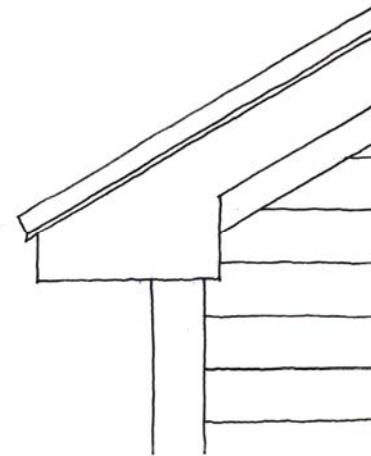

*The "pork chop" treatment is inappropriate as there is no horizontal return.*

## **E. Materials and Finishes**

1. Exterior walls may be finished in any of the following:
  - a. Wood or cement siding (e.g., Hardiplank or equal).
  - b. Modular brick. King size and other non-standard brick sizes should be avoided.
2. Roofs may be constructed of any of the following materials:
  - a. Dimensional composition shingles, which may feature a ridge vent for ventilation purposes.
  - b. Galvanized metal and pre-finished metal panels, in standing seam, batten seam, or 5-V crimp pattern. Colors should be muted neutral or gray tones.
3. Flat roofs, where appropriate, may be of any built-up or membrane roofing system.



## **VI. Historic Restoration**

### **A. Intent and General Provisions**

This section discusses appropriate treatments for historic properties within Old Sixth Ward and contains general restoration principles as well as resource information on the types of historic construction found within the District. In general, the provisions of this section apply to restoration projects where the intent is to respect and repair the historic integrity of the structure.

The following principles apply to restoration projects:

- Respect the historic design character of a building. Identify and keep original elements; remove later modifications that are not in character.
- Some alterations that date from before World War II may have acquired historic significance in their own right and should be retained. More recent alterations that are not historically significant should be removed.
- In-kind repair (repair using the same materials) should be used for damaged or deteriorated features.
- In-kind replacement (similar materials, details, and finishes) should be used only when repair is not feasible.
- If new features are added or additions are constructed, they should have minimal effect on the original features. The new work should be differentiated from the original and should be compatible in terms of size, scale, proportions, and massing. For example, where the walls of an addition join the historic building, the new construction should be

stepped-in at the corners (the location of the original, vertical cornerboard trim) to delineate the old from the new construction. The wall cladding for the addition should be different than the historic building cladding to delineate the addition. This can be accomplished by using a different type of lap siding or vertical board and batten siding (wood or HardiPlank). The roof of the addition should not be higher than the roof of the historic building.

The general principles outlined above are derived from the Secretary of the Interior's Standards for the Treatment of Historic Properties, codified in 1995 as 36 CFR Part 68.

Please note that The Secretary of the Interior's Standards for the Treatment of Historic Properties are only regulatory for projects receiving federal grant funds; otherwise, they are intended only as general guidance for work on any historic building. Mandatory observance of these standards may also be linked to certain local grant and incentive programs.

## **B. Structure Types and Distinctive Features**

There are many types and styles of structures found within the Old Sixth Ward Protected Historic District. This information is presented as a resource to assist in the accurate and appropriate restoration of a similar building in the District.

The following pages document the principal historic building types found in Old Sixth Ward, along with a list of distinctive features and some representative examples of the type.

## **C. Structure Types**

The structure type of a house not only helps to determine the age of the building, but is also the basic framework that creates the general form of the building. Structure types in the District include, in alphabetical order:

1. Bungalow
2. Central Hall
3. Corner Store
4. Cross Gable
5. Double Tenant Cottage
6. Duplex
7. Extended Shotgun
8. Garage Apartment
9. I-Cottage
10. L-Cottage
11. Raised Cottage
12. Side Hall
13. Shotgun
14. Three Bay

## 1. Bungalow

Built within the District: 1905-1945

Distinctive features:

- A deep porch across the entire façade or a partial width porch; porch can be inset under main roof or applied to front, and features its own gable roof.
- Low-pitched roof with rafters often exposed.
- Decorative beams or brackets under gable eaves.
- Porch roof typically supported by tapered square columns.
- Often a large front-facing gable spanning entire porch width.
- Generally one story; Airplane Bungalow features a single room on second level (two-story).
- Windows of wood and 1 over 1 type, sometimes with decorative upper sashes or screens.
- Horizontal, wood lap or teardrop (#117) siding (although there are a few brick examples).

The bungalow represents part of a general movement toward simplification following the excesses of the Victorian period. The typical bungalow floor plan is more informal than earlier plans. One generally enters directly into the main living area of the home. Houses of this type often emphasize the hearth, and a fireplace is generally visible upon entry.



## 2. Central Hall

(also known as Dog Trot, Gulf Coast Colonial, or Five Bay)

Built within the District: 1850-1890

Distinctive features:

- Often a deep porch across front. This porch can be inset as in a Gulf Coast Colonial or applied to the front. Later porches highly ornamental. Earlier porches were less ornamental.
- High-pitched roof with side gables and enclosed eaves. Gulf Coast Colonials had no eave or gable overhanging.
- Gulf Coast Colonials usually had Greek Revival doorways with fanlight and sidelights.
- Porch typically supported by square chamfered or turned posts. Later examples with decorative bracket and frieze work
- Never with hipped roof or front gable.
- Generally one or 1 ½ story.
- Windows of wood and any of the following types: usually 4 over 4, 2 over 2, and even 1 over 1.
- Shutters or wood-framed screens.
- Wood, horizontal siding.



2203 Kane Street William Pasch Residence Built circa 1888

### 3. Corner Store

Built within the District: 1850-1950

Distinctive features:

- Shop located on a corner lot.
- Often with housing attached for owners of shop. Housing can be on the side or on the upper level.
- Constructed of brick or wood.
- Large shop windows along front or main Façade.
- One or two stories.
- Windows of wood and any of the following types: 2 over 2, or 1 over 1.
- Plateglass with divisions and transom windows above storefront windows on first floor; also on upper floor.

Corner stores were built throughout the District. These structures served the local community prior to the prevalence of the automobile. The businesses were often grocery stores, but also included drug stores, hardware stores, and one candy store.



#### 4. Cross Gable

Built within the District: 1890-1920

Distinctive features:

- Usually with a wrap-around porch connecting the two cross gable roofs.
- High-pitched roof with side gables and enclosed eaves. One prominent front facing gable.
- Decorative trim under eave overhang with small windows in gables. Sometimes stained glass.
- Porch typically supported by square chamfered or turned posts. Often with decorative bracket and frieze work. Later porches highly ornamented. Earlier porches were more simple. Examples built after 1900 usually had round Doric porch columns.
- Often with hipped roof with intersecting gable roof(s).
- Generally one or two stories.
- Windows of wood and any of the following types:
  - 2 over 2 or 1 over 1.
- Shutters or wood-framed screens.
- Horizontal wood siding. Sometimes decorative shingle-work in gable fronts.



## 5. Double Tenant House

Built within the District: 1860-1880

Distinctive features:

- Often a deep porch across front, usually inset as in a Gulf Coast Colonial.
- High-pitched roof with side gables and enclosed eaves. Gulf Coast Colonials had no eave overhanging.
- Decorative trim under eave overhang with small windows in gables.
- Twin front doors on front façade.
- Porch typically supported by square chamfered or turned posts. Rarely with decorative bracket and frieze work. Later porches highly ornamented. Earlier porches are less ornamented.
- Never with hipped roof.
- Generally one or 1 ½ story.
- Windows of wood and any of the following types:  
6 over 6, 4 over 4.
- Shutters or wood-framed screens.
- Horizontal wood siding.



## 6. Duplex

Built within the District: 1910-1940

Distinctive features:

- Often a small bracketed porch, or pediment over entry doors.
- Low-pitched roof with open or closed eaves. Often with gable front roof. Rarely with hipped roof.
- Small window or vent in gable front.
- Porch typically supported by simple brackets.
- Generally one story.
- Windows of wood and any of the following types:  
2 over 2, 1 over 1.
- Shutters or wood-framed Screens (plain or decorative).
- Horizontal wood lap or teardrop (#117) siding.  
(Note: lumber yards often refer to teardrop siding as #117.)





## 7. Extended Shotgun

Built within the District: 1880-1920

Distinctive features:

- Front porch can extend full width of house or half width of the house and porch is inset under main roof.
- High-pitched roof with gables and enclosed eaves. One prominent front facing gable.
- Decorative trim under eave overhang with small windows in gables. Sometimes stained glass.
- Porch typically supported by square chamfered or turned posts. Often with decorative bracket and frieze work. Later porches highly ornamented. Earlier porches were less ornamented.
- Never with hipped roof.
- Generally one or 1 ½ story .
- Windows of wood and any of the following types:  
4 over 4, 2 over 2.
- Shutters or wood-framed screens.
- Horizontal wood siding. Often with decorative shingles in gables.



## 8. Garage Apartment

Built within the District: 1920-1950

Distinctive features:

- Often a small bracketed porch or pediment over entry door.
- Both high or low-pitched roof with side gables. Sometimes eaves have exposed rafters. • Sometimes comes features a hipped roof.
- Generally two stories.
- Wooden garage doors on lower level.
- Sometimes built with exterior staircase to second level.
- Windows of wood and any of the following types:  
4 over 4, 2 over 2, but mostly 1 over 1.
- Shutters or wood-framed screens.
- Horizontal wood siding or board and batten siding.



## 9. I-House

Built within the District: 1870-1890

Distinctive features:

- Often with a deep double-galleried porch across the entire front façade but sometimes a partial width porch which is centered.
- High-pitched roof with gables and enclosed eaves. Sometimes with hipped roof.
- Sometimes with decorative trim under eave overhang with small windows in gables. Rarely with stained glass.
- Floor plan resembles an 'I', hence the style name, often with a rear service wing of one or two stories.
- Porch typically supported by square chamfered or turned posts. Often with decorative bracket and frieze work. Later porches highly ornamented. Earlier porches were less ornamented.
- Generally two stories.
- Windows of wood and any of the following types:
  - 4 over 4, 2 over 2
- Shutters or wood-framed screens.
- Horizontal wood siding.



## 10. L-Cottage

Built within the District: 1880-1890

Distinctive features:

- Often a deep porch in front, adjoining front gable ell. This porch is usually applied to the front.
- High-pitched roof with gables and enclosed eaves. One prominent front facing gable.
- Decorative trim under eave overhang with small windows in gables. Sometimes stained glass.
- Porch typically supported by square chamfered or turned posts. Often with decorative bracket and frieze work. Later porches highly ornamented. Earlier porches were less ornamented. Examples built after 1900 usually had round Doric porch columns.
- Never with hipped roof.
- Floor plan resembles an “L”, hence the style name.
- Generally one or 1 ½ story .
- Windows of wood and any of the following types:  
4 over 4, 2 over 2, rarely 1 over 1
- Shutters or wood-framed screens.
- Horizontal wood siding. Often with decorative shingles in gable fronts.



## 11. Raised Cottage

Built within the District: 1880-1910

Distinctive features:

- Often a deep porch across front or adjoining front gable ell. This porch can be inset under main roof or applied to the front.
- High-pitched roof with gables and enclosed eaves. Usually with prominent front facing gable.
- Sometimes with decorative trim under eave overhang with small windows in gables. Sometimes stained glass. Gulf Coast Colonials had no gable overhang.
- Porch typically supported by square chamfered or turned posts. Often with decorative bracket and frieze work. Later porches highly ornamented. Earlier porches were less ornamented. Examples built after 1900 usually had round Doric porch columns.
- Rarely with hipped roof.
- Generally one or 1 ½ story .
- Windows of wood and any of the following types:  
4 over 4, 2 over 2, and 1 over 1.
- Shutters or wood-framed screens.
- Horizontal wood siding. Sometimes with decorative shingles in gable fronts



## 12. Side Hall

Built within the District: 1880-1900

Distinctive features:

- Often a deep porch across front. This is usually applied to the front and may wrap around the corner. Sometimes double-galleried.
- High-pitched roof with gables and enclosed eaves. One front prominent facing gable.
- Often with decorative trim under eave overhang with small windows in gables. Often with stained glass.
- Porch typically supported by square chamfered or turned posts. Often with decorative bracket and frieze work. Later porches highly ornamented. Earlier porches were less ornamented.
- Rarely with hipped roof.
- Generally one or two stories.
- Windows of wood and any of the following types:
  - 4 over 4, 2 over 2
- Shutters or wood-framed screens.
- Horizontal wood siding. Often with decorative shingles in gable fronts



### 13. Shotgun

Built within the District: 1870-1910

Distinctive features:

- Often a deep porch across front. This porch can be inset under the main roof or applied to the front.
- High-pitched roof with gables and enclosed eaves. One prominent front facing gable.
- Decorative trim under eave overhang with small windows in gables. Sometimes stained glass.
- Porch typically supported by square chamfered or turned posts. Often with decorative bracket and frieze work. Later porches highly ornamented. Earlier porches were less ornamented.
- Sometimes with hipped roof.
- Generally one story.
- Windows of wood and any of the following types: 6 over 6, 4 over 4, 2 over 2; rarely 1 over 1.
- Shutters or wood-framed screens.
- Horizontal wood siding. Sometimes with decorative shingle-work in gables.



## 14. Three-Bay

Built within the District: 1860-1880

Distinctive features:

- Often a deep porch across entire façade of house or a partial width porch which is centered. This porch can be inset in Gulf Coast Colonial examples or applied to the front.
- High-pitched roof with gables and enclosed eaves. One front facing gable. Gulf Coast Colonials had no gable overhangs.
- Rarely with decorative trim under eave overhang with small windows in gables
- Porch typically supported by square chamfered or turned posts. Often with decorative bracket and frieze work. Later porches highly ornamented. Earlier porches were less ornamented.
- Sometimes with a hipped roof and small dormer on front slope of roof.
- Generally one or 1 ½ story .
- Windows of wood and any of the following types:  
6 over 6, 4 over 4, or 2 over 2
- Shutters or wood-framed screens.
- Horizontal wood siding, rear wings sometimes had board and batten siding.





## **Design Guidelines for Old Sixth Ward**

### **VIII. Appendices**

**A. Resource Materials**

**B. A Village in the City**

**C. Listing of Documented Houses**

**D. Illustrated Glossary**

## Appendix A

### Resource Materials

There exists a considerable amount of resource material that will be helpful to anyone considering a project in Old Sixth Ward. While these materials are too numerous to list here in detail, this Appendix will serve to at least refer the user to more comprehensive sources.

Most of the pertinent information may be accessed through the Planning and Development Department's section of the City of Houston web site at:

<http://www.houstontx.gov/planning/index.html>

Key links in the menu include:

Development Regulations

Historic Preservation/Houston Archeological and Historical Commission (HAHC)

The latter link will provide access to a range of detailed information including frequently asked questions, application forms, descriptions of the Certificate of Appropriateness process, and information about the Houston Archaeological and Historical Commission. The HAHC page includes a schedule of meeting dates.

A diagram of the application process for a Certificate of Appropriateness in Old Sixth Ward is shown on the following page.

The City of Houston Code of Ordinances may also be accessed through the Online Library of the Municipal Code Corporation at:

<http://www.municode.com/Resources/OnlineLibrary.asp>

On this website, select the appropriate state and city and an index to the entire code of ordinances will appear. The Historic Preservation Ordinance is included in Chapter 33.

## Process for Protected Old Sixth Ward Historic District

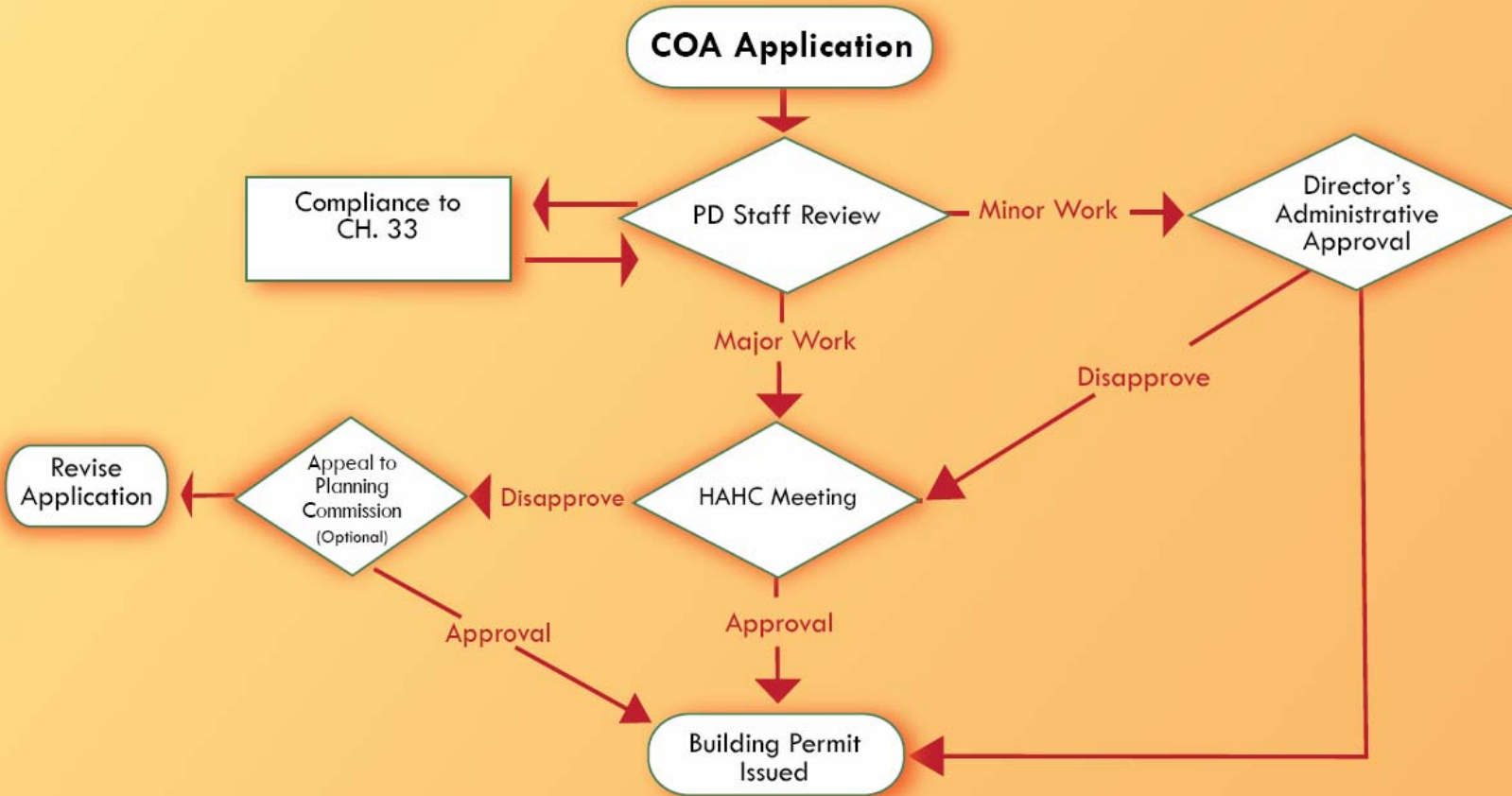

## Appendix B

### A Village in the City

Home to approximately 2,000 Houstonians, the area now called the Old Sixth Ward was originally part of a two-league Mexican land grant made in 1824 to John Austin. On July 6, 1838, two years after John K., Augustus C., and Charlotte B. Allen founded the town of Houston, S.P. Hollingsworth filed a survey of the area in which he divided the land into large, narrow tracts that ran northward from Buffalo Bayou. By January 1839, portions of the Hollingsworth survey located in the future Old Sixth Ward had been conveyed to several prominent Houstonians, including W. R. Baker, James S. Holman, Nathan Kempton, and Henry Allen. By 1858, W. R. Baker and his friends owned or held mortgages on most of the land in this area. Baker engaged the County Surveyor, Samuel West, to restructure his holdings by converting the whole area into a lot and block system. The new survey was laid out to true north, varying from downtown, which was platted at a 45-degree angle to true north. The first sale after the re-platting took place on January 31, 1859, when Baker transferred several blocks to W. W. Leeland. Subsequent lot and block sales followed Baker's plat, which remains in use today.

For many years, W. R. Baker served as President of the Houston and Texas Central Railroad. Its route approached Houston from the northwest, and the railroad's success greatly influenced the growth of the neighborhood, which attracted immigrants seeking employment. Long noted for its ethnic and economic diversity, the neighborhood has at various times been home to Swedish, German, English, Irish, French, Swiss, Italian, Polish, Eastern European, Jewish, African, Chinese, Vietnamese, Mexican, Latin American, and Scottish immigrants. The 1870 census indicates that everyone

who lived in this area worked either for the railroad or in a related enterprise, such as construction or retail services.

In 1871, Glenwood Cemetery opened at the western edge of the area. It provided a natural, protective boundary that continues in force today. In 1872, Washington Avenue was graded and the number of businesses located there increased. By 1878, the Houston Street Railway (trolley) extended to Washington Avenue, where the business district was known as "Uptown," in contrast to the Market Square area, which was known as "Downtown." A bird's-eye view of the area drawn in the early 1890s shows the neighborhood to have been fully developed with a structure on almost every lot. By the early 1900s, the Sixth Ward was a fully developed community complete with a fire station, a public school, stores, saloons, churches, and industrial establishments.

The *Houston Chronicle* newspaper lauded "Fourth Ward North," as Sixth Ward was originally called, as one of the finest and "healthful" places to live in Houston. The area enjoyed the highest elevation in Houston as well as abundant artesian water, fed by the Beauchamp Springs. Its residents enjoyed proximity to downtown and other attractions such as the popular Highland Park resort at the corner of Houston Avenue and White Oak Drive, which had excellent swimming and boating facilities. Fourth Ward North was so popular that the *Chronicle* ran a weekly section on it for several years.

The majority of the houses standing today were built in the 1870s, 1880s, and 1890s as modest, one-story frame cottages occupied by single families. During the 1880s, the majority of the families living in the neighborhood were of German descent. Many of those families

lived on farms in the country in northwest Houston where the Spring Branch, Rosslyn, Timbergrove, and Oak Forest subdivisions now stand. In keeping with German tradition, they built houses in Sixth Ward as “town homes.” They would use these houses while selling their farm produce at the city market downtown, doing their annual shopping, socializing, or attending theatres or opera houses downtown. They used timber from their farms to build these houses.

During the late 19th century, more than half of the houses were owner-occupied. The vernacular character of these dwellings was enhanced by decorative millwork, usually applied to the front porches. As the 20th century progressed, new housing reflected changes in architectural styles. Bungalows were built among the cottages, but the essential character of the neighborhood did not change. During World War II, many of the original owners had passed on and their houses were converted from single to multi-family tenant dwellings, often owned by absentee landlords. Since achieving recognition as both a nationally and a locally designated historic district, the Old Sixth Ward has witnessed the restoration of many homes to single-family occupancy.

Today’s Old Sixth Ward is often described by visiting historians as a small village in the shadow of downtown Houston. The Old Sixth Ward is a complete community with historic churches, corner stores, and even a school and cemetery. It is with the intent to preserve this valuable cultural resource that the design guidelines and historic district were created.

## **Appendix C**

### **Listing of Documented Structures**

The most current list of contributing, potentially contributing, and non-contributing buildings in the District can be found on the City of Houston Planning Department website:

[http://www.houstontx.gov/planning/historic\\_pres/Sixth\\_Ward/OSWMap.pdf](http://www.houstontx.gov/planning/historic_pres/Sixth_Ward/OSWMap.pdf)

## Appendix D

### Illustrated Glossary

*Alteration:* any change to the exterior of a building, structure, object or site. Alteration shall include, but is not limited to, changing to a different kind, type or size of roofing or siding materials; changing, eliminating, or adding exterior doors, door frames, windows, window frames, shutters, fences, railings, columns, beams, walls, porches, steps, porte-cocheres, balconies, or ornamentation; or the dismantling, moving or removing of any exterior feature. Alteration does not include ordinary maintenance and repair.

*Archaeological:* relating to the study of past human behavior through use of material remains of historic and prehistoric origin.

*Archaeological site:* a property or location designated by the city council on which there exists material remains of past life or past life activities that occurred on the property or at the location.

*Balustrade:* a railing or low wall consisting of a handrail on balusters (small supporting posts) and a base rail.

*Base:* the lowest part of a building or column.

*Bead Board:* a traditional paneling comprised of individual tongue-and-groove boards with a half round bead along one edge, frequently used as a finish material for ceilings, porch soffit, and wainscoting.

*Block:* one or more lots, tracts, or parcels of land bounded by streets, easements, rights-of-way, or other physical features or a combination thereof.

*Blockface:* the portion of a block that abuts a street.

*Building:* any structure used or intended for supporting or sheltering any use or occupancy.

*Building permit:* an official document or certificate issued by the building official authorizing performance of a specified activity, including the alteration, restoration, rehabilitation, construction, relocation or demolition of a building, structure, or object.

*Capital:* the top decorative portion of a column or pilaster.

*Certificate of Appropriateness:* a current and valid permit issued by the HAHC or the planning official, as applicable, authorizing the issuance of a building permit for construction, alteration, rehabilitation, restoration, relocation or demolition required by this article.

*Compatible:* the condition in which two or more structures or objects demonstrate a harmonious and consistent relation distinguished by scale, material, compositional treatment, and other features that add to the character of the scene.



*The residence located at 803 Sawyer is compatible.*

*Conservation plan:* an inventory and analysis of historic resources within a geographic area of the city that has been designated or proposed for designation as an historic district pursuant to the provisions of this article, which contains standards for alteration, rehabilitation, restoration, construction, relocation and demolition of buildings, structures, objects or sites in an historic district.

*Construction:* the act of expanding an existing building, structure or object or the erection of a new building, structure or object on a lot, site, or other property.

*Context:* the surrounding environment of a building or site, including other structures, site features, landscape, and streets.

*Contributing:* a building, structure, object, or site that reinforces the cultural, architectural, or historical significance of the historic district in which it is located.

*Contributing structure:* a building, structure, object, or site that is identified as contributing to the designation of the historic district in which it is located.



*This residence on Sabine Street is a contributing structure*

*Corbel:* a bracket of stone, wood, or metal projecting from the side of a wall and serving to support a cornice, the spring of an arch, a balustrade, or other element.

*Cornice:* a projecting ornamental molding along the top of a building.

*Demolition:* an act or process that destroys in whole or in part any building, structure, object, or site.

*Designation:* the formal recognition by the city council of a building, structure, object, site, or district as historically, architecturally, culturally, or archaeologically significant to the city, state, nation, or region.

#### *Door*

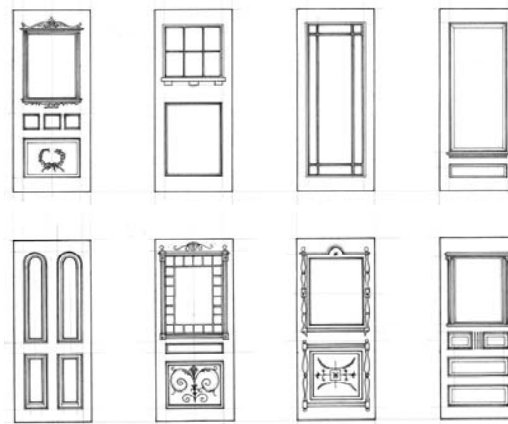

*Doors in the District display a range of designs with recessed panels; some of these may contain glass lights.*



*Dormer:* a window set upright in a sloping roof; the roofed projection in which this window is set.

*Economic return:* a profit or capital appreciation from use or ownership of a building, structure, object, or site that accrues from investment or labor.

*Elevation:* a “head-on” drawing of a building façade or object, without any allowance for perspective. An elevation drawing will be in a fixed proportion to the measurement on the actual building.

*Excavation:* to expose, uncover, or remove by digging, cutting, or hollowing out.

*Exterior feature:* an element of the architectural character and general arrangement of the external portion of a building, structure, or object (including building material), which is visible from a public right-of-way.

*Façade:* a face of a building, usually referring to the main entry side of the structure.

*Fascia:* a horizontal band of vertical face trim located under the bottom roof line.

*Free-standing sign:* a detached sign that is supported by one or more columns, uprights, or braces extended from the ground or from an object on the ground; or, a detached sign that is erected on the ground.

*Gable:* the triangular wall enclosed by the sloping ends of a ridged roof.

*Gable ornament:* a decorative trim added at the apex of a (usually front facing) gable on structures built in the later part of the 19<sup>th</sup> century.

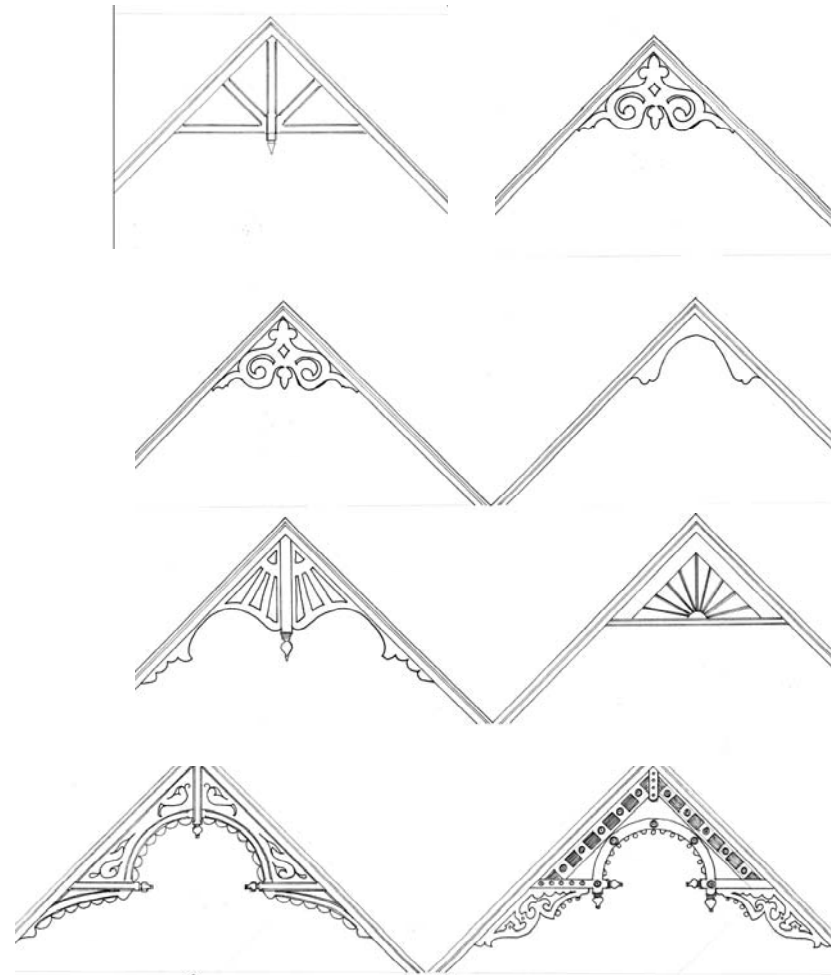

*Examples of gable ornaments found within the District.*

*Gable window:* a decorative window located within the gables of a structure.

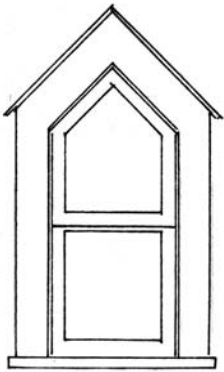

*This example of a gable window has an upper detail to coordinate with the gable.*

*HAHC:* the Houston Archaeological and Historical Commission.

*Historic district:* a geographical area designated by the city council that possesses a significant concentration, linkage, or continuity of buildings, structures, objects, or sites united by historical, cultural, architectural, or archaeological significance to the city, state, nation, or region.

*Historic property:* a building, structure, object, or site significant in American history, architecture, engineering, archaeology, or culture at the national, state, or local level.

*Historic resource:* generally, a historic property; includes architectural, historical, and archaeological properties as well as landscape features.

*Hood molding:* a projecting molding or trim around the top of a doorway or window to throw off the rain.

*Incompatible:* a non-harmonious and inconsistent relation between two or more structures or objects, distinguished by scale, material, compositional treatment, and other features that do not add to the character of the scene.



*The Residence at 1904 Decatur is an incompatible construction.*

*Integrity:* the authenticity of a property's historic identity, evidenced by survival of physical characteristics that existed during the property's historic or prehistoric period.

*Inventory:* a list of historic resources that have been identified and evaluated as meeting specified criteria of significance.

*Landmark:* any individual building, structure, object, or site designated by the city council for its historical, cultural, architectural, or archaeological significance in the city, state, nation, or region.

*Lattice:* an openwork screen or grill made of interlocking or overlapping strips.

*Mandatory repair:* a repair of a building or structure that is necessary in order to comply with Article IX of Chapter 10 of the City Code as evidenced by an order of the hearing official or the building and standards commission or by a citation.

*Mimic:* to copy or imitate closely.

*Molding:* a shaped strip of wood, metal, brick, or other material that is used in an ornamental or functional way.

*Muntin:* a strip of wood or metal used to separate and hold panes of glass in a window.

*Non-contributing:* a building, structure, object, or site that does not reinforce the cultural, architectural, or historical significance of the historic district in which it is located.

*Non-contributing structure:* a building, structure, object, or site that is identified as non-contributing to the designation of the historic district in which it is located.



*Example: A non-contributing structure.*

*Object:* a material thing of a functional, aesthetic, cultural, historical, or scientific value that may be moveable by nature or design, yet is related to a specific setting or environment.

*Ordinary maintenance and repair:* any work to correct or prevent deterioration, decay, or damage to a building, structure, object, or site (or any part thereof), provided that the work does not change the design, character, texture, or material of any exterior feature and does not constitute an "alteration" as defined above.

*Porch*

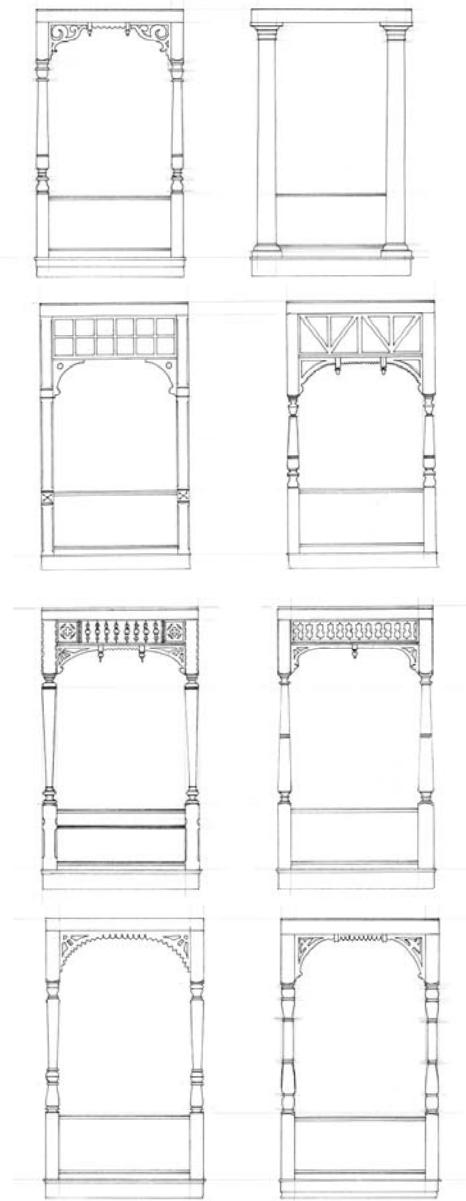

*Porch posts*

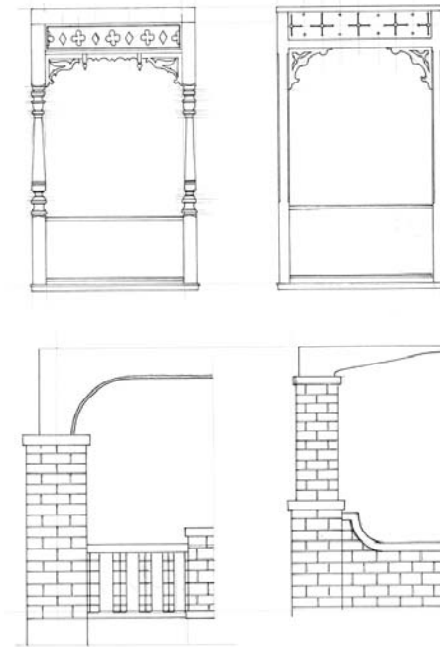

*Potentially contributing:* a building, structure, object or site with incompatible alterations or deteriorating conditions that, if reversed, would reinforce the cultural, architectural, or historical significance of the historic district in which it is located.

*Potentially contributing structure:* a building, structure, object, or site with incompatible alterations or deteriorating conditions, that if reversed, would reinforce the significance of the historic district in which it is located.



*The residence at 1904 Kane is a potentially contributing structure.*

*Preserve:* to keep in a perfect or unaltered condition.

*Preservation:* the act or process of applying measures to sustain the existing form, integrity, and material of a building or structure and the existing form and vegetation cover of a site. It may include initial

stabilization work, where necessary, as well as ongoing maintenance of the historic building materials.

*Public right-of-way:* an area, at grade level, dedicated to the public for the passage of people or goods.

*Qualified curatorial association:* an organized and permanent non-profit institution, essentially educational or aesthetic in purpose, with professional staff, that owns and utilizes tangible objects, cares for them, and exhibits them to the public on some regular schedule, provided that the institution meets the requirements of the Council of Texas Archaeologists' Guidelines (Curation Standards and Procedures), 1992 edition, as may be amended or updated from time to time.

*Real property records:* the applicable records of a county in which conveyances of real property are recorded.

*Reconstruct:* to create again. A building, room or detail may be reproduced in its exact detail and appearance as it once existed. Accurate reconstruction, such as in the case of a porch, requires good evidence of the original design.

*Rehabilitation:* the act or process of returning a building, structure, object, or site to a state of utility that makes possible an efficient contemporary use while preserving those portions or exterior features that are historically, architecturally and culturally significant.

*Relocation:* any change in the location of a building, structure, or object.

*Remodel:* to remake or make over. In a remodeling, the appearance is changed by adding or removing elements from the structure. Often these changes are not reversible.

*Restore*: to bring back to a previous condition.

*Restoration*: the act or process of accurately recovering the form and details of a building, structure, object or site and its setting as it appeared at a particular period of time by means of the removal of later work, or by the replacement of missing earlier work or both.

*Screen door*

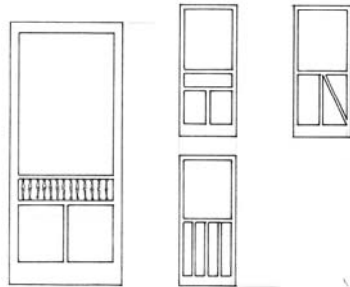

*Shutter*

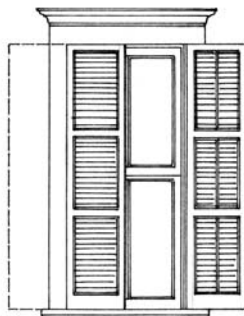

*Sidelight*: a vertical window on one or two sides of a central door.

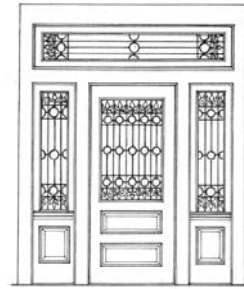

*This door has a sidelight on each side of the door.*

*Siding*

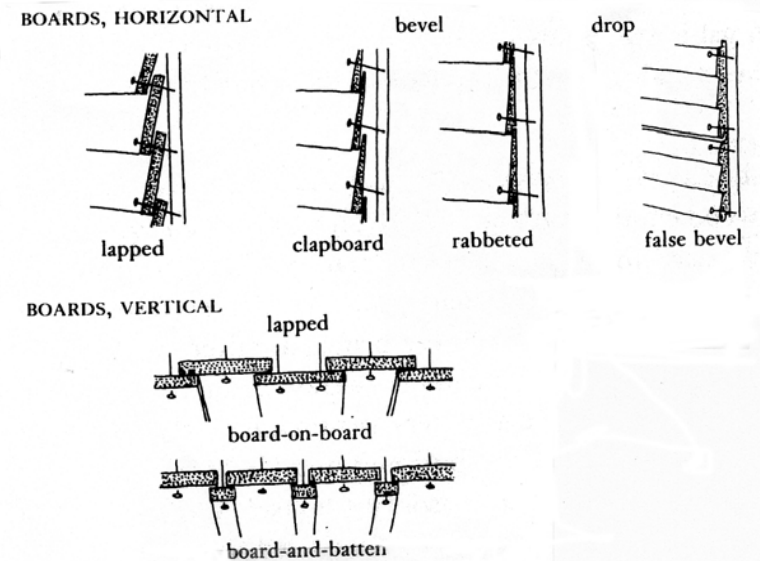

*A Field Guide to American Houses, Virginia & Lee McAlester, 1984, p. 39*

*Sill:* the horizontal bottom member of a window or door frame.

*Site:* property upon which a significant event occurred, including but not limited to any land, building, or natural resource where prehistoric or historic occupations or activities occurred; or the location of buildings and structures, whether standing, ruined, demolished, or relocated, where the location retains historical, architectural, or archaeological value and integrity.

*Stabilize:* to make resistant to change in condition. A building is usually stabilized to retard deterioration until it can be repaired. A weather resistant closure and a safe structural system are minimum stabilization efforts.

*Structure:* that which is built or constructed; an edifice or building of any kind, or any piece of work artificially built up or composed of parts joined together in some definite manner.

*Tract:* a contiguous parcel of land under common ownership.

*Transom:* a horizontal cross-bar in a window, over a door, or between a door and the window above it. It may also refer to a window above a door or other window.

*Transom*

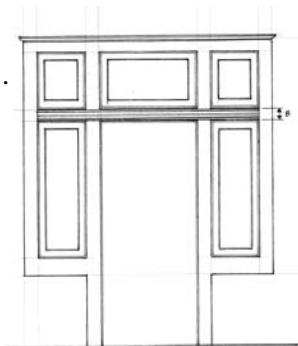

*This door has an unusual triple transom.*

*Window*

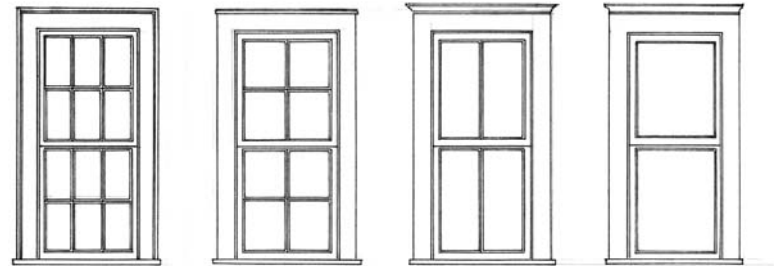

*Windows are frequently described by the number of divided lights (panes of glass) in each sash. Shown here from left to right are a 6-over-6, 4-over-4, 2-over-2, and a 1-over-1.*

*A more decorative upper sash is also fairly common.*

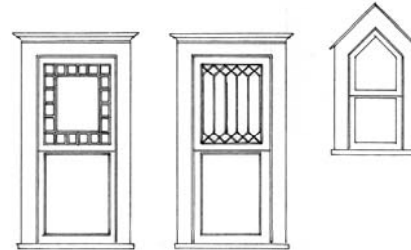

*Window screen*

