

SECTION 5: MEASURABLE STANDARDS AND RELATED GUIDELINES FOR ADDITIONS AND NEW CONSTRUCTION

The City of Houston's historic preservation ordinance requires changes to existing buildings, including additions and all new construction within the historic districts, to be compatible with contributing buildings in the context area in terms of massing, form, scale, and proportions. Property owners, builders, and architects have asked for more specific guidance to help them plan projects that are likely to be approved by the HAHC. In response to those requests, this document includes measurable (quantitative) standards which do not require interpretation; the standards are either met or they are not.

These standards were developed using the City of Houston's Geographic Information Systems data about contributing properties in the three Houston Heights Historic Districts, as well as input and feedback from the community, gathered over more than 12 months through numerous public meetings, a historic district-specific Compatible Design Survey, and comments from individuals.

This section includes measurable standards for additions and new (infill) construction. Additional qualitative design guidelines for additions are provided in Section 6. Additional qualitative guidelines for new construction are provided in Section 7.

IN THIS SECTION

- Introduction.....5-2**
- Measurable Standards.....5-3**
 - Lot Size and Orientation 5-4
 - Maximum Lot Coverage 5-5
 - Building Orientation..... 5-6
 - Front Setbacks (for New Construction) 5-7
 - Side Setbacks (for Additions and New Construction) 5-9
 - Rear Setbacks 5-10
 - Building Size and Compatibility 5-11
 - Mass, Form, and Scale..... 5-14
 - Maximum Floor Area Ratio..... 5-15
 - Side Wall Length and Insets..... 5-16
 - Eave Height 5-17
 - Building Wall (Plate) Height 5-18
 - Porch Eave Height 5-19
 - Front Wall Width and Insets 5-20
 - Front Porch Width and Depth 5-21
 - Detached Garage Ridge Height 5-22



A streetcape with front porches and yards encourages neighborly interaction



A streetcape of townhouses

INTRODUCTION

The collection of buildings along a blockface creates a streetscape. The size and shape of those buildings, along with their distance from the street and orientation, together affect the overall look and feel of the neighborhood.

The way that buildings relate to the street and each other affects the way that people relate to them, as well. For example, consider a block full of tall townhouses with front-loading garages and little or no lawn and landscaping between the buildings and the street. Contrast that with a neighborhood where one- and two-story houses are all set back from the street far enough to create a sizeable front yard, with room for plenty of flowers and shrubs, but close enough to the sidewalk so that neighbors sitting on their porches can converse with passersby.

To maintain a consistent streetscape, buildings must be appropriately sized and sited on their lots. In order to determine what is appropriate for the Houston Heights Historic Districts, the City has evaluated the historic buildings within the district to determine typical lot and building sizes, massing, orientation, and setback from the street.

MEASURABLE STANDARDS

The following pages contain the quantitative (numerical) standards for the Houston Heights Historic Districts. These standards are to be used for all context areas, unless the applicant can provide adequate documentation that contributing buildings in the context area typically exceed these standards.

If an applicant wishes to propose alternative numbers in such a situation, they must provide the following evidence:

- A list of all contributing buildings in the context area, by street address
- For each building, the applicable measurement (to the nearest inch)
- A statement explaining how the measurements were collected; i.e., using a physical measuring tool or a digital approach
- The proposed alternative numerical standard

The Planning staff in the Historic Preservation Office will verify the data presented by the applicant and provide HAHC with the applicant's data and, if necessary, any corrections to that data.

HAHC will consider the data presented and determine whether or not to use the applicant's proposed numerical standards when considering the application.

- HAHC may consider mean and/or median values, but is not obligated to do so.
- The City's Historic Preservation Ordinance defines *typical* as "being within commonly occurring values in a group. Extreme values within a group are not necessarily typical of that group." HAHC may choose to disregard outliers, such as a single especially large building in a context area.

PLEASE NOTE:

Some larger historic homes were built but have been lost over the years, particularly along and near Heights Boulevard. Buildings which are no longer extant may not be considered for comparison purposes in a COA application. Only those contributing buildings still standing are used to determine compatibility.

Lot Size and Orientation

Although lot sizes vary, most lots in the Houston Heights Historic Districts are 50 feet wide by 132 feet deep, or 6,600 square feet.

Maximum Lot Coverage

Lot coverage is a measure of the percentage of a lot's surface that is covered by buildings, expressed as a decimal (such as .44). Lot coverage is calculated by dividing the total area of included building footprints by the total area of the lot, where building footprints are measured at the outside of exterior walls.

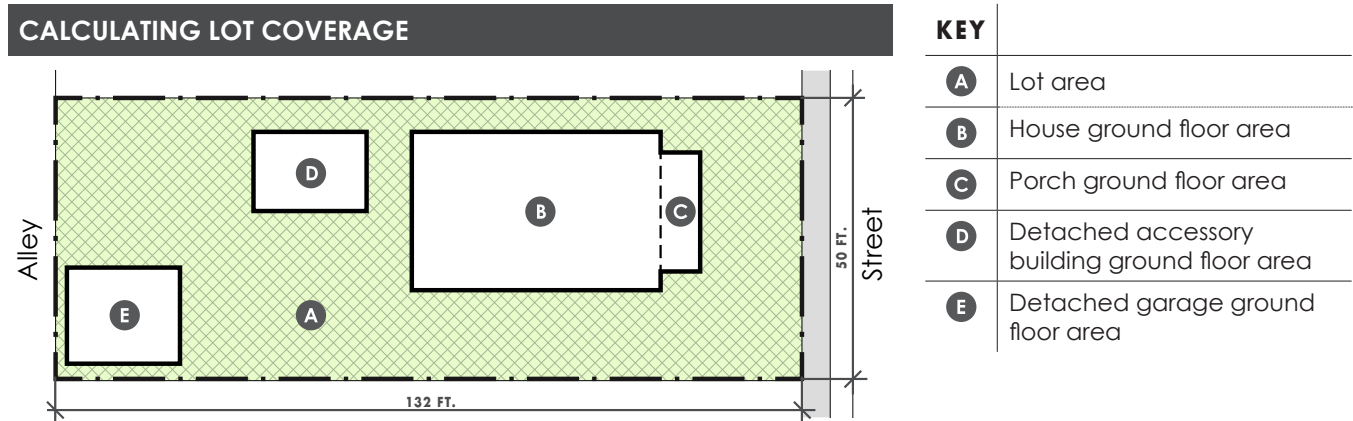

LOT SIZE	MAXIMUM LOT COVERAGE
<4000	.44 (44%)
4000-4999	.44 (44%)
5000-5999	.42 (42%)
6000-6999	.40 (40%)
7000-7999	.38 (38%)
8000+	.38 (38%)

Include these in lot coverage calculations:

- primary structures (such as houses or other main buildings)
- attached garages and storage space
- detached garage (area over 400 square feet)*

Exclude these from lot coverage calculations:

- detached garage (up to 400 square feet)*
- roof overhangs
- open porches; uncovered decks or patios
- detached accessory structures other than garages or garage apartments
- pavement and driveways

* When calculating lot coverage, you may exclude that portion of the footprint of a detached garage which measures 400 square

feet or less. For example, if the footprint area of detached garage is 316 square feet, you may exclude the entire 316 square feet from the lot coverage calculation. If the footprint area of the detached garage measures 482 square feet, you may exclude 400 square feet, leaving 82 square feet to be included.

Building Orientation

The way in which buildings address the street is an important characteristic of the streetscape. Most buildings in the Houston Heights Historic Districts face the street, with very few exceptions. In most cases, front doors also face the street, although some houses have inset porches with side-facing doors that open onto the front-facing porch. Some commercial buildings, which are located on corner lots, have cutaway doors at the corner of the building.

For Existing Buildings with Additions

4.1 Maintain front-facing primary facades, porches, and entry doors.

- Do not remove a front porch.
- Maintain primary entry doors that were originally side-facing and open to the porch.
- Preserve corner doors on commercial buildings where these exist.

For New Construction

4.2 Design the building with a primary entry door that faces the street, rather than a side property line.

- Site a building with its front wall parallel to the street.
- A residential or commercial building on a corner lot should have a clearly identifiable primary entrance.



Orient the face of a building to the street.

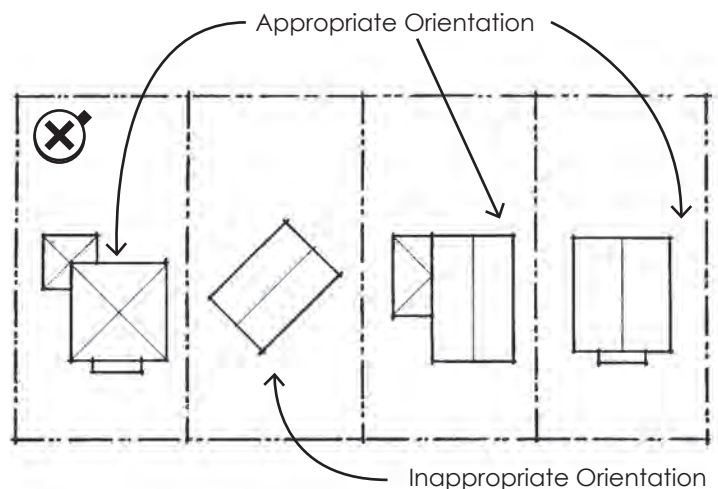

A new building should be oriented to be compatible with contributing buildings in the context area

Front Setbacks (for New Construction)

A setback is the distance from the property line to the front or side wall, porch, or other exterior feature of a building. The amount of setback at the front of a residential building determines the size of the front yard and affects how the building relates to the street.

Measurable standards for front setbacks are provided on the following pages. If deed restrictions or minimum building line requirements also apply to a property, the most restrictive standard shall be used.

Calculating Front Setbacks

To determine the range of front setbacks within a context area:

1. Using the district inventory, identify all contributing structures within the context area.
2. Determine the front setback for each contributing property in the context area.

Option 1: take physical measurements.

- Secure permission to enter your neighbors' yards. *Do not enter private property without permission.*
- Use a tape measure to measure the front setback for each property to the nearest full inch.
- Record the front setback for each property.

Option 2: Use a digital tool such as Google Maps to measure distance.

- Search for the property by street address.
- Zoom in on the map as much as possible.
- Switch to satellite view.
- Right-click anywhere on the map. An option box should appear. Left-click to select "Measure distance."
- Left-click with the point of the arrow cursor positioned at the edge of the street.
- Left-click with the point of the arrow cursor positioned at the closest point on the building.
- Record the front setback for the property, in feet to the second decimal place.
- Convert the measurement from decimal feet to feet and inches. For example:
33.95 feet =
33 feet + .95 feet =
33 feet + (.95 feet x 12 inches/foot) =
33 feet + 11.4 inches =
33 feet, 11 inches (rounded to the nearest full inch)

FRONT SETBACK RANGE

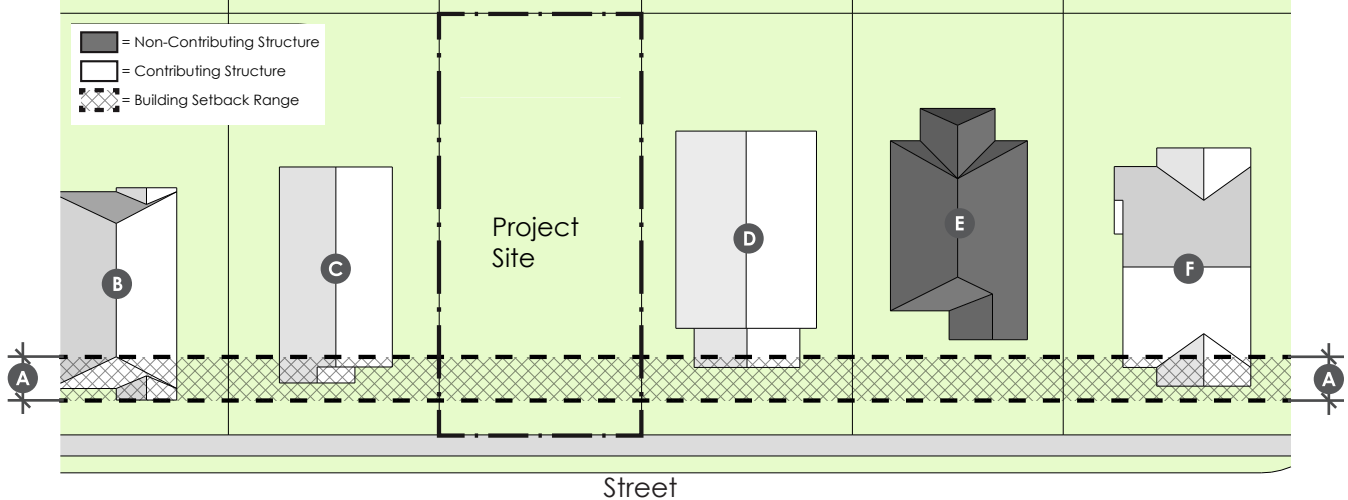

KEY	MEASUREMENT	APPLICATION
A	RANGE	Locate the front of the primary building within the range of front setbacks for contributing buildings within the context area.

When all contributing buildings in the context area have approximately the same front setback, make new construction consistent with that.

When front setbacks vary for contributing buildings within the context area, place new construction within the range of front setbacks, as shown above.

Example:

1) Determine the front setbacks of the contributing buildings in the context area.

- B = 11 ft.
- C = 16 ft.
- D = 18 ft.
- E = Noncontributing building (does not count)
- F = 12 ft.

2) Find the shortest and longest contributing setbacks to determine the acceptable range.

- B = 11 ft. (shortest contributing front setback)
- D = 18 ft. (longest contributing front setback)
- A = 11–18 ft. is the front setback range

Side Setbacks (for Additions and New Construction)

New structures and additions must be located at a minimum distance from the front and side property lines. Those distances, also known as setbacks, are measured from the property line to the closest wall, porch, or exterior feature.

The City of Houston requires a minimum three-foot side setback for all properties. On a corner lot, the building must be at least 10 feet from the street on street-facing sides.

Within the Houston Heights Historic Districts, the side setback is increased to a minimum of five feet on each side and a cumulative total of 10 feet for one-story houses and 15 feet for two-story houses.

This standard was established in response to numerous complaints from property owners about their neighbors building tall walls at the three-foot property line, resulting in a loss of privacy and sunlight. In combination with eave height limits, these side setback requirements are intended to move the building mass toward the center of the lot and away from the property lines.

Please note the following important points:

- If the existing house is less than five feet from the property line:
 - A one-story addition can match the side setback of the existing house or a three-foot side setback, whichever is greater.
 - A two-story addition must have a minimum five-foot setback.
- For the purpose of determining maximum allowable eave height, the side setback for the entire building is measured at the portion of the building that is closest to the property line.
- Buildings on corner lots should be consistent with the front setbacks of existing contributing buildings on both front and side streets.

SIDE SETBACKS

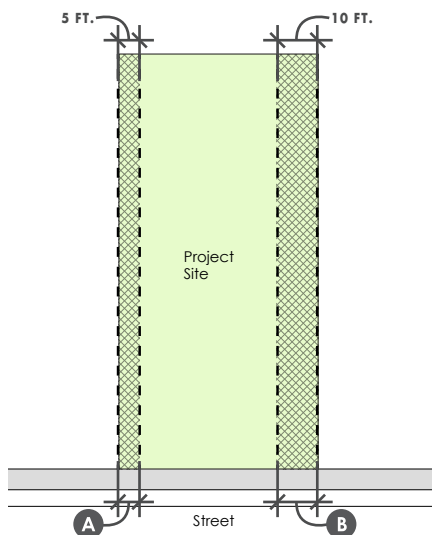

KEY	MEASUREMENT	APPLICATION
A	5 FT.	Minimum distance between the side wall and the property line.
B	REMAINING	Difference between minimum side setback of 5' and minimum cumulative side setback
C	10 FT.	Minimum cumulative side setback for a one-story house
	15 FT.	Minimum cumulative side setback for a two-story house

Note: This diagram shows just one example of a side setback configuration.

Rear Setbacks

The City of Houston requires a minimum setback of three feet from the rear property line for all properties, except under the following circumstances:

- A front-facing garage which is located with its rear wall at the alley may have a zero-foot setback.
- An alley-loading garage generally must be set back a minimum of 20 feet from an opposing alley-loading garage door, the rear wall of a front-facing garage, or a fence; a 24-foot clearance is preferred.

Building Size and Compatibility

The Houston Heights Historic Districts contain both contributing and noncontributing structures. Contributing buildings, which are used to determine compatibility for alterations to existing buildings, as well as additions and new construction, are mostly one- and two-story single-family residential buildings. The districts also contains some contributing commercial buildings, which are also mostly one or two stories in height. Most of these historic commercial buildings are located in Houston Heights Historic District East.

The districts also contain noncontributing buildings of various sizes, some of which are quite large. These include houses, multi-family apartment complexes or condominiums, and commercial buildings. Many of these were constructed before protections for the historic districts were established through the historic preservation ordinance.

Some buildings have been expanded through additions. The presence of an addition does not necessarily affect a building's contributing status, but an addition that greatly encroaches on a historic building or that has resulted in the removal of substantial historic material may cause a building to be reclassified as noncontributing at some point in the future, if the district inventory is updated. Such a reclassification may result in the loss of eligibility for the Historic Site Tax Exemption program.

Because the City's historic preservation ordinance has evolved over time, some additions to contributing buildings which were previously approved by the HAHC might not be approved today. Each COA application is considered based on its own merits, the unique conditions of the property in question, and the ordinance criteria and design guidelines in place at the time of application.

For Additions to Contributing Buildings

Because contributing structures are the most important buildings in the historic district, they must remain prominent. That means that an addition should be visually subordinate to the original building.

4.3 Keep additions visually subordinate to the historic building.

- Design the addition to be smaller than the contributing structure.
- Locate the addition where it will not be highly visible from the public right-of-way.

4.4 Manage the addition's scale (size) and proportions (relationships between building elements).

- A rear addition may be one story or two stories tall. Plate heights should be similar to those of the existing building.
- One-story side additions may be added to a one-story or two-story building. Two-story side additions may be added only to two-story buildings.
- The width of a side addition cannot be greater than the width of the front wall of the existing building, especially if the addition is taller than the contributing building.
- The first-floor finished-floor height of the addition cannot be taller than the foundation of the existing building or exceed 30".
- Eave heights for an addition should be the same or lower than the existing building when the addition is attached directly to the existing building. When the existing building and addition are separated by a connector, the eave height may be 12–18" taller, as long as the addition remains visually subordinate.
- The second-floor plate height of a two-story addition should be lower than the first-floor plate height.

For Additions to Noncontributing Buildings

Additions to noncontributing structures are required to be compatible with the scale and proportion of the contributing buildings in the context area. This applies to the building overall as well as to individual building elements.

4.5 Design an appropriately sized addition.

- Design the addition with overall height, porch eave height, main roof eave height, and ceiling (plate) heights that are consistent with the existing noncontributing structure or with contributing buildings in the context area.
- Use header heights for doors and windows that are similar to those of contributing buildings in the context area.

For New Construction

Because contributing structures are the most important buildings in the historic district, they must remain prominent. New construction must be compatible with the scale and proportion of contributing buildings in the context area. This applies to the building overall, as well as to individual building elements. New buildings should not overshadow contributing structures within the context area.

4.6 Design a new building to be compatible with the scale and proportion of contributing buildings in the context area.

- A new building may be one story or two stories in height.
- First-floor finished floor height may not exceed 30".
- Use wall cladding materials, such as siding or brick, that are traditionally sized. Do not use oversized cladding materials.
- Design the building with porch eave height, main roof eave height, and ceiling (plate) heights that are consistent with contributing buildings in the context area.
- Use header heights for doors and windows that are similar to contributing buildings in the context area.

Mass, Form, and Scale

Massing, or architectural form, is the overall shape and volume of a building. The proportion of *solid* surfaces (walls, roof) to *voids* (windows, doors, porches) also affects the perception of form and volume. A building's size and shape have as much effect on its overall appearance as do stylistic details and decorative accents. In architectural terms, size and shape are more precisely described by the terms mass, form, and scale. These three characteristics are among the most important character-defining features of a historic building. (For more information about mass, form, and scale, see Section 2.)

Most contributing houses in the Houston Heights Historic Districts are relatively small, with simple rectangular shapes. Subordinate building elements are mostly rectangular and, generally, project from the main house in the form of front porches and small additions. Where additions increase both the size and complexity of contributing buildings, they are located far enough from the street to be visually subordinate to the traditional forms of the original houses.

For Additions

4.7 Preserve the original walls of the building.

Walls enclose and make visible the forms that make up a building. In architecture terms, a wall may be a single plane (that is, a flat continuous surface) or it may be articulated, with areas that are set in or project out.

4.8 Preserve the original corners of the building, wherever those occur.

4.9 Preserve the shape of the roof;.

4.10 Preserve any porches from the period of significance (1891–1947).

4.11 Maintain the historic heights, widths, and proportions of building elements and architectural details (including doors and windows).

For Additions and New Construction

4.12 Avoid complex building forms or roof shapes, such as those typically found on 21st century houses.

4.13 Use traditional proportions of solid walls to voids (windows, doors, and porches).

Maximum Floor Area Ratio

Floor Area Ratio (FAR) is the ratio of eligible building area to lot size. FAR is calculated by dividing the total square footage of conditioned and unconditioned space in eligible buildings by the square footage of the lot, with the result expressed as a two-digit decimal (such as 0.44). FAR applies to both new infill construction and additions to existing buildings (contributing and noncontributing).

Include these in FAR calculations:

- primary structures (such as houses or other main buildings)
- attached garages and storage space
- detached garage (area over 400 square feet)*
- detached garage apartment (area over 400 square feet)**
- attics with dormers in new additions, new construction, and noncontributing houses

Exclude these from FAR calculations:

- detached garage (area up to 400 square feet)*
- detached garage apartment (area up to 400 square feet)**
- attics in existing contributing buildings
- attics without dormers in new additions, new construction, or noncontributing houses
- roof overhangs
- open porches; uncovered decks or patios
- detached accessory structures, other than garages and garage apartments
- pavement and driveways

* When calculating FAR, you may exclude that portion of a detached garage which measures 400 square feet or less. For example, if the area of detached garage is 316 square feet, you may exclude the entire 316 square feet from the lot coverage calculation. If the area of the detached garage measures 482 square feet, you may exclude 400 square feet, leaving 82 square feet to be included.

** Additionally, you may exclude that portion of a detached garage apartment which measures 400 square feet or less.

CALCULATING FLOOR AREA RATIO

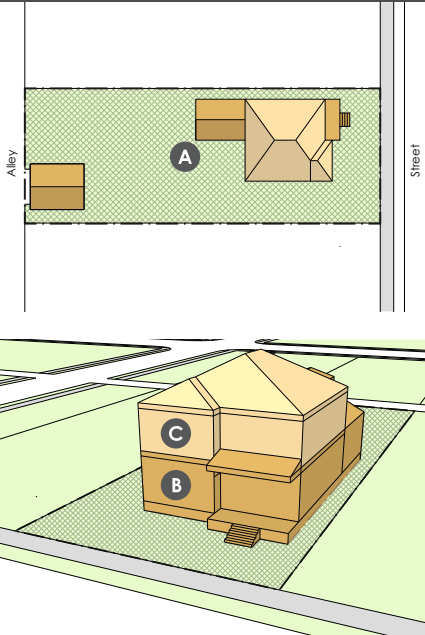

A	Lot Area
B	1st Floor Area
C	2nd Floor Area

Example:
 1st Floor Area = 1,307 sf.
 + 2nd Floor Area = 1,280 sf.

 Total Building Area = 2,335 sf
 ÷ Lot Area = 6,600 sf.

 Floor Area Ratio (FAR) = 0.35

LOT SIZE	MAXIMUM FAR
<4000	.48
4000-4999	.48
5000-5999	.46
6000-6999	.44
7000-7999	.42
8000+	.40

Side Wall Length and Insets

Maximum overall wall lengths have been established for front walls and side walls. In addition, these design standards establish how long a wall can be before a portion of a wall must be inset relative to the rest of the wall. These measurements apply to both one-story and two-story buildings.

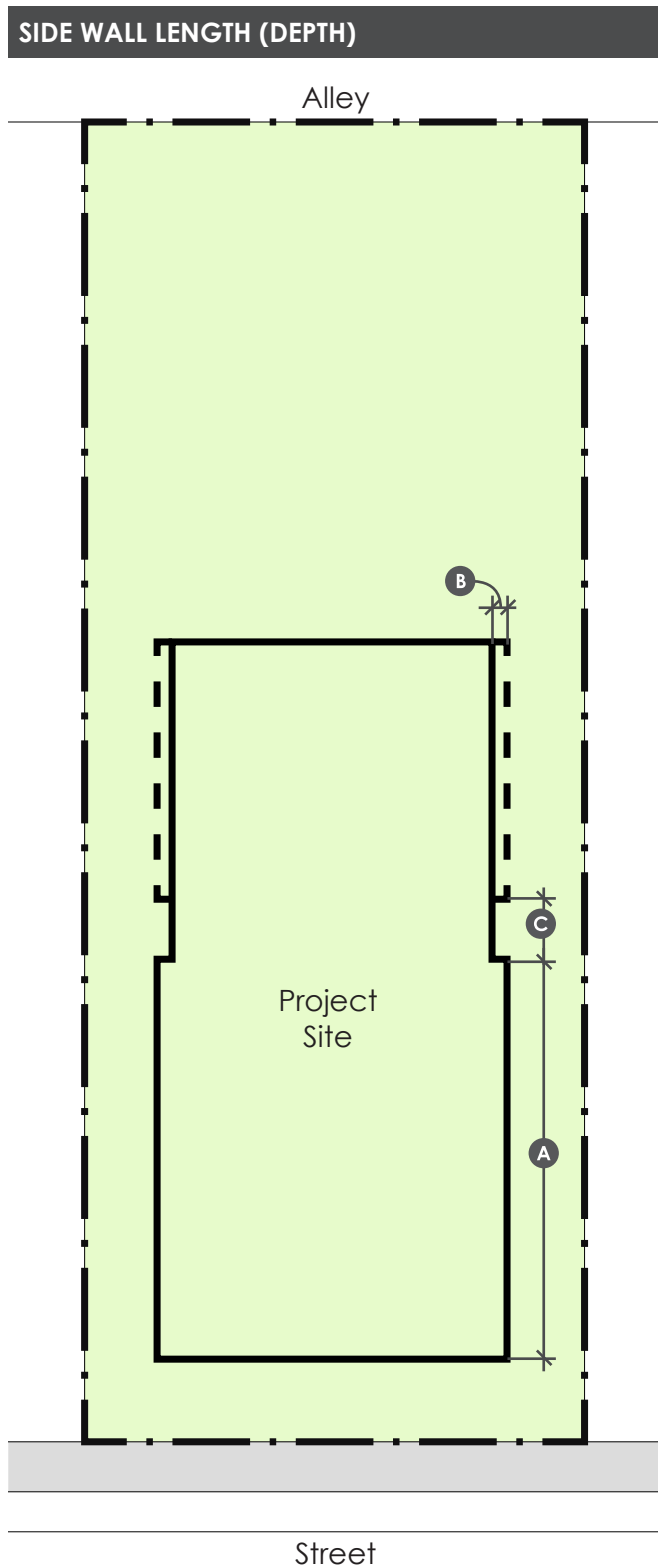

SIDE WALL LENGTH (1-STORY BUILDING)

KEY	MEASUREMENT	APPLICATION
A	50 FT.	Maximum side wall length without inset (1-story)
	40 FT.	Maximum side wall length without inset (2-story)
B	1.5 FT.	Minimum depth of inset section of side wall
C	6 FT.	Minimum length of inset section of side wall

Eave Height

An eave is the overhanging lower edge of a roof. Eave height is the vertical distance from the ground to the eave, as measured from existing natural grade relative to a fixed point in the right-of-way, such as the crown of the street or a manhole cover. Measure to the eave where it is parallel to the ground.

Eaves on an addition should be the same height or lower than the eaves for the same floor of the existing contributing house. The eaves of a new garage should be the same height or lower than the house.

For new construction, the maximum eave height is established at the minimum side setback from the property line; it can increase one foot (1') in height for each one foot (1') increase in side setback up to the maximum allowable eave height. Smaller increases in side setback qualify for the equivalent increase in eave height; for example, an additional seven inches of side setback would result in a maximum of 12' 7" eave height for a one-story roof.

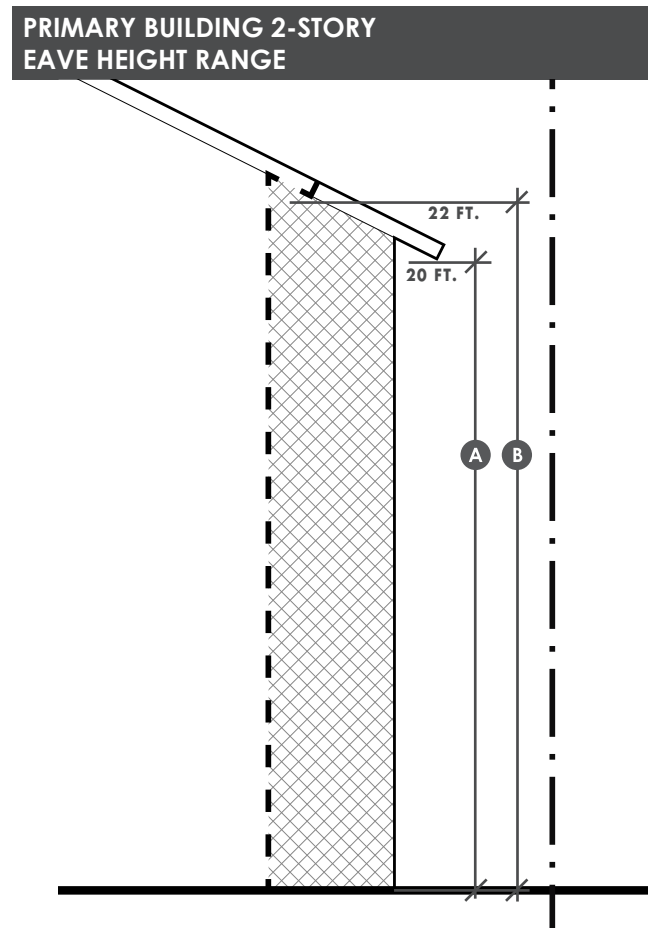
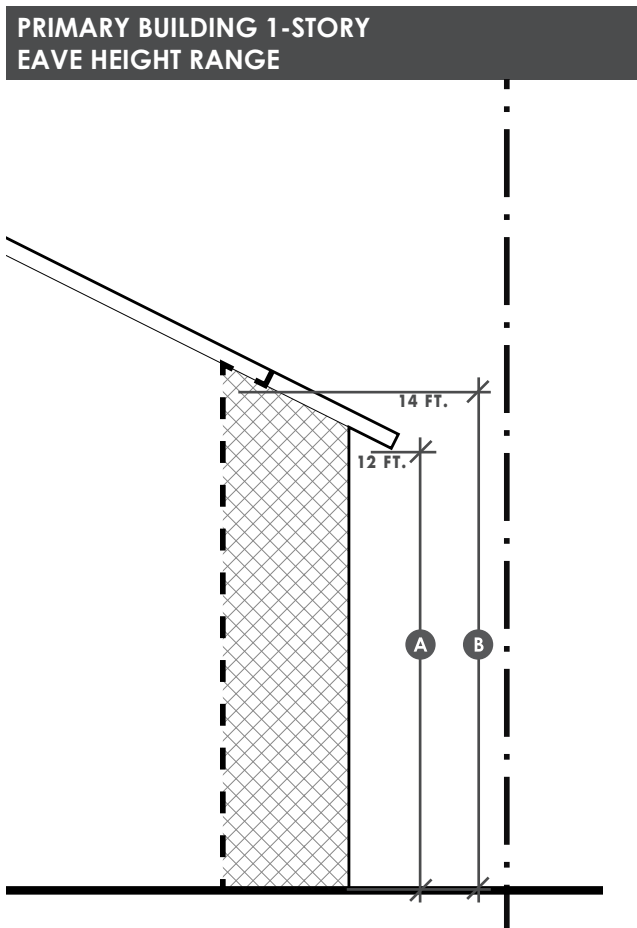

KEY	MEASUREMENT	APPLICATION
A	12 FT.	Maximum 1-story eave height at the 5 FT. minimum side setback
B	14 FT.	Maximum 1-story eave height at 7 FT. or greater side setback

KEY	MEASUREMENT	APPLICATION
A	20 FT.	Maximum 2-story eave height at the 5 FT. minimum side setback
B	22 FT.	Maximum 2-story eave height at 7 FT. or greater side setback

Building Wall (Plate) Height

Plate height is the distance from the subfloor of a building to the top of the framed wall; in other words, it is the height of one “floor” of the building.

Additions

Plate heights for additions should appear to be the same or lower than those of the existing house. Taller ceilings, if desired, can be achieved with a lower foundation, or if the ceiling is vaulted or otherwise tucked into the roof structure.

New Construction

There are no plate height limits for one-story new construction.

Two-story new construction must not exceed the plate height limits shown below.

KEY	MEASUREMENT	APPLICATION
A	30 INCH.	Maximum foundation height
B	10 FT.	Maximum first floor plate height
C	9 FT.	Maximum second floor plate height

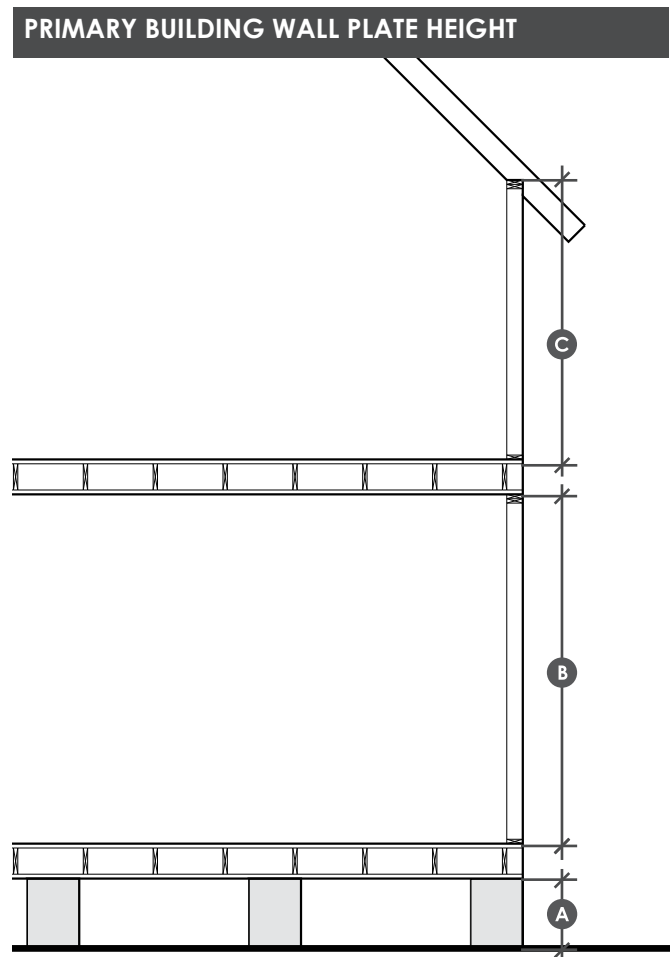

Porch Eave Height

A porch may be included as part of an addition. A porch eave is the overhanging lower edge of the porch roof. Eave height is the vertical distance from the ground to the eave, as measured from existing natural grade relative to a fixed point in the right-of-way, such as the crown of the street or a manhole cover.

Porch roofs should be lower than the main roof of the building, unless the main roof extends over the porch. Ideally, the porch beam will skim the tops of the windows.

KEY	MEASUREMENT	APPLICATION
A	9-11 FT.	Minimum and maximum 1-story porch eave height.

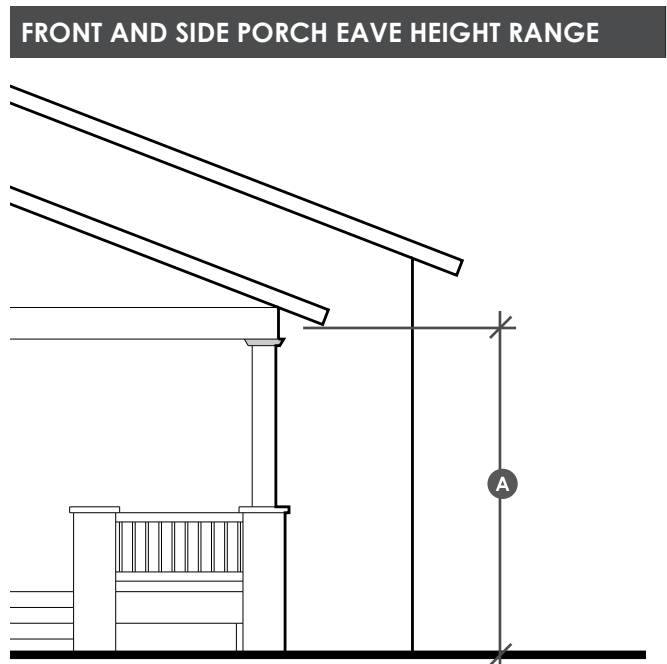

Front Wall Width and Insets

Maximum overall wall widths have been established for front walls. In addition, within those overall maximum widths, these design standards establish how wide a wall can be before it must be inset, with a portion of a wall set farther in or out relative to the rest of the wall. These measurements apply to both one-story and two-story buildings.

Overall building widths are dependent on the width of the lot. The maximum width of a one-story building on a 50'-wide lot with a 10' minimum cumulative side setback is 40'. As a lot gets wider, the building can be wider, to a point; for every two feet of additional lot width, the building can be one foot wider. Smaller increases in lot width qualify for the equivalent increase in building width, using a 2:1 ratio; for example, a 60'-wide lot could have in a maximum 50'-wide building.

Note; Use this standard when designing new construction or if you are proposing to widen a noncontributing house. Widening the front wall of a contributing house is not allowed.

KEY	MEASUREMENT	APPLICATION
A	30 FT.	Maximum front wall width before inset
B	4 FT.	Minimum width of inset section of front wall
C	35 FT.	Maximum width of building for lots \leq 50 ft wide
	50 FT.	Maximum width of building for lots $>$ 50 ft wide

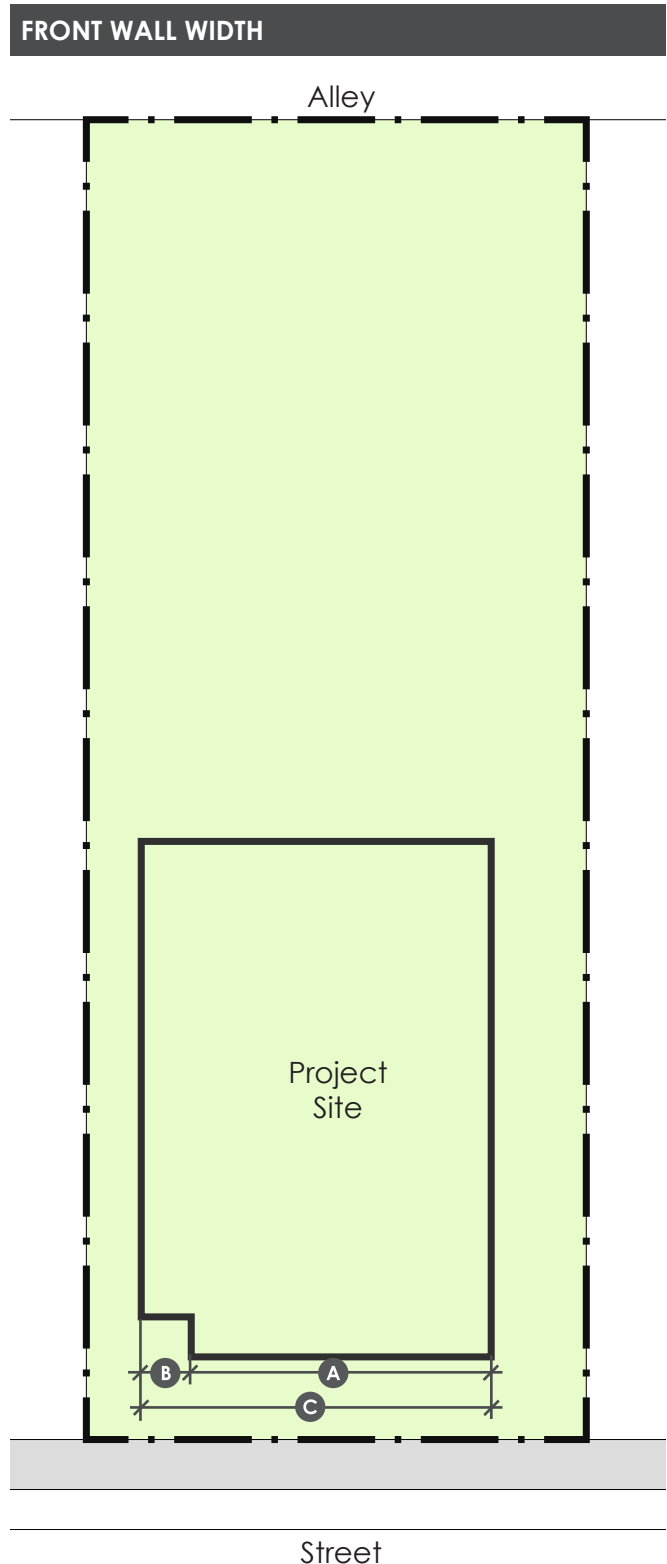

Front Porch Width and Depth

A one-story front porch must be *at least half as wide* as the front of the house. A two-story front porch may be *no more than half as wide* as the front of the house.

If a portion of the front wall is inset, the overall width (including the width of the inset section) is used for this calculation. The width of a porch is measured between the corners of the porch roof.

A front porch must be at least 6' deep; an 8' depth is recommended to accommodate porch columns while retaining usable space. Porch depth is measured from the front of the porch deck at the center of the steps, along a line perpendicular to the front edge of the porch deck, to the closest front wall of the house.

FRONT WALL-TO-PORCH WIDTH

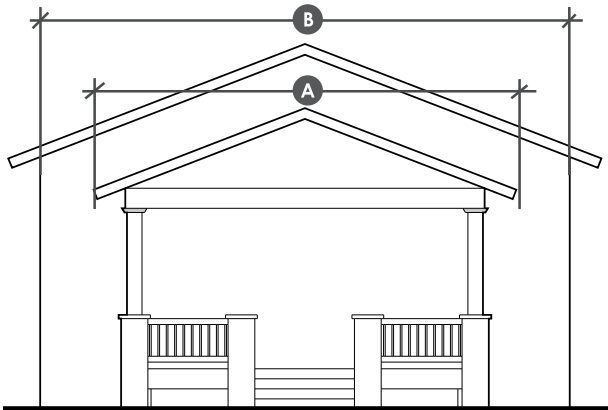

A	Porch Width
B	House Width at Front Wall

KEY	MEASUREMENT	APPLICATION
A	50%	Minimum width of front wall that is covered by porch

FRONT PORCH DEPTH

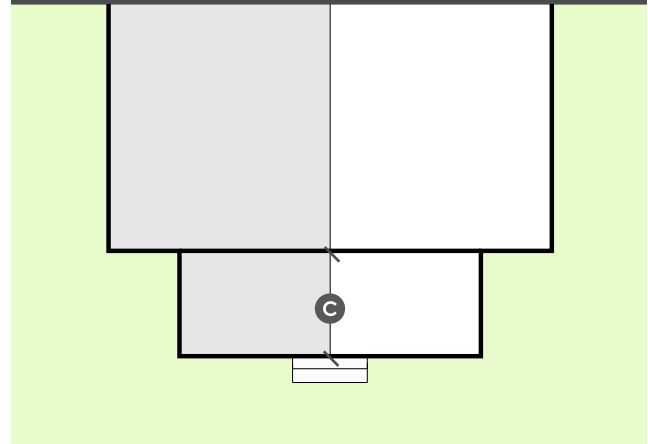

KEY	MEASUREMENT	APPLICATION
C	6 FT.	Minimum depth of front porch

Example:

Porch Width = 18 ft.
 ÷ House Width at Front Wall = 26 ft.
 Porch Front Wall Percentage = 69 %

Detached Garage Ridge Height

Ridge height is the distance from grade to the top of ridge. These measurements apply to both one-story and two-story detached garages/garage apartments. For new attached garages, use the measurable standards for additions and new construction found elsewhere in this section.

GARAGE 1-STORY RIDGE HEIGHT

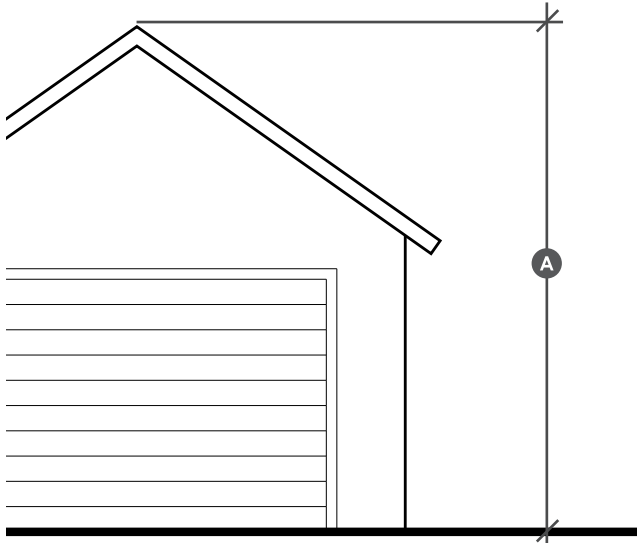

KEY	MEASUREMENT	APPLICATION
A	16 FT.	Maximum 1-story garage ridge height

GARAGE 2-STORY RIDGE HEIGHT

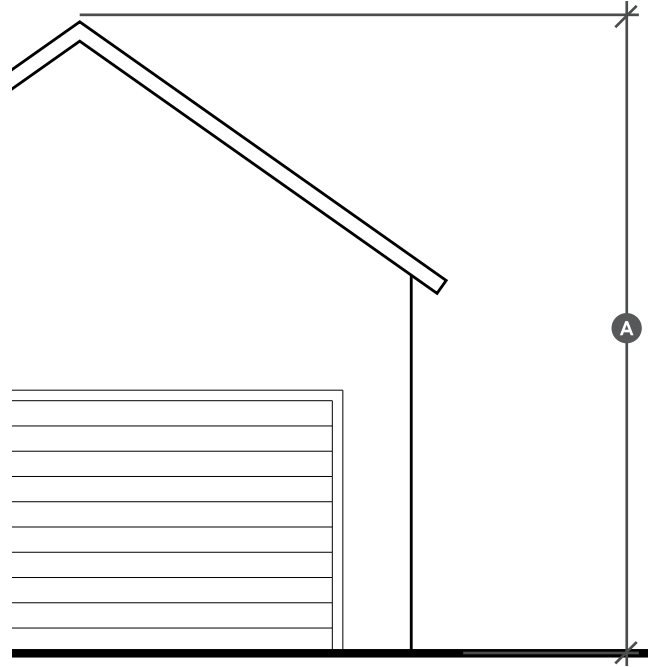

KEY	MEASUREMENT	APPLICATION
A	26 FT.	Maximum 2-story garage ridge height (for garage apartment)